



## **SBS – 700**

# Multi-Functional Oscilloscope User Manual

***Read the Users Manual prior to using the Meter***

***Pay special attention to the “Safety Precautions” section of the manual.***

 **Attention**

**Attention mark may be displayed while meter is in use. Meter can be damaged or important Data may be lost if the Meter is not properly used.**

 **Warning**

**Warning mark may be displayed while meter is in use, using the meter on voltages above safety ratings may cause serious personal injury or fatal death.**

**[Safety Symbol]**

Table lists and describes the safety symbols shown on the Meter Display or in the User Manual.

 : DC (Direct Current or Voltage)

 : AC (Alternating Current or Voltage)

 : DC and AC

 : Earth Ground

 : Double Insulation

 : Power Supply OFF

 : Power Supply ON

 : Warning on Electric Shock

 : Warning on Danger

 : Category II 1000V Overload Protection(Multi-meter Function )

 : Category III 600V Overload Protection(Multi-meter Function )

 : Category III 300V Overload Protection(Scope Function)

**[Notes for Safe Operation]**

**WARNING: USE EXTREME CAUTION IN THE OPERATION OF THE METER**  
Improper use of the Meter can result in injury or death.

Follow all safeguards in this manual, in addition to the normal safety precaution used in working with electrical circuits.

**DO NOT SERVICE the Meter if you are not qualified to do so.**

**[ WARNING  ]**

- Pay attention when testing conditions exceeded 60V DC, 30V AC rms or 42.4V AC Peak that can cause electrical shock. Do not connect the ground wire to a voltage higher than 0V DC, 30V AC rms or 42.4V AC Peak.
- Use only the accessories supplied with the Meter. Rechargeable Battery Pack, AC Power Adapter and Internal Charger, Test Leads, Probes, Logic/Signal Cable set. Warranty will not cover Meter Measurement failure or damage from improper accessories other than those supplied by the manufacturer with the Meter.
- Connect and disconnect properly. Test leads, Probes or Test Cables must always be connected to the meter before connecting into circuits to be measured. Always remove leads from test circuit prior to disconnecting from the meter.

- Meters with rechargeable NiMH battery packs must only use manufacturer supplied replacement batteries. Remove the AC Power Adapter, Test Leads, Probes and Cables from the Meter when replace the Battery.
- When the Battery Warning Symbol is blinking on the display, the measured values may be in error. Replace with new batteries or recharge the unit.
- Observe all input terminal ratings. Observe all ratings and markings on the Meter. Refer to the users manual for detailed information.

[⚠ Max Input Voltages]

- Scope Input: 300V CATIII.

-Multi-Meter Input: 600V CATIII.

- Do not apply voltage when measuring in the Ohm(resistance) or Capacitance Meter Mode.
- Do not use the meter in or near explosive, flammable, wet or damp environments.
- Do not use Meter if the Case Cover is opened for any reason.
- Fuses must be replaced with only the proper size and rating as the original.
- Do not expose internal circuits.

**[ATTENTION]**

- Before testing for Resistance, Capacitance. Continuity or Diode, disconnect any power supply at the circuit being tested and discharge High Voltage Rated Capacitors.
- Do not attempt Voltage measurements while measuring Currents.

**[ENVIRONMENT]**

The Meter is designed Indoor use in the following environmental conditions:

- Operating Temperature: 0°C ~ 50°C
- Guaranteed Accuracy Temperature: 23 0°C +/- 5°C
- Operating Humidity: 80% R.H. or less
- Storage Temperature: 0°C ~ 70°C
- Altitude : 2000m
- Pollution Degree: 2









**WEEE (Waste Electrical and Electronic Equipment) (2002/96/EC)**

Meter complies to WEEE (2002/96/EC) requirements.

Do not dispose Electrical / Electronic devices with other trash.



# Table of Contents

	Page
<b>1. Introduction</b> .....	6
Major Functions .....	6
• Front View .....	6
• Keys and Function Description .....	7
• LCD Display .....	9
• Measurement Input Terminals.....	14
• Rear and Side View.....	16
• Voltage Warning, Input Warning, Power, Battery , Auto Power Off, Battery Save, Back Light Display, Auto / Manual Ranging.....	16
• Menu .....	18
• Help, Data Hold .....	20
• Auto Hold, Save/ Recall .....	21
<b>2. How to measure Main Function</b> .....	21
• <b>Oscilloscope</b> .....	21
<input type="checkbox"/> Channel.....	22
<input type="checkbox"/> Trigger.....	24
<input type="checkbox"/> Measure.....	25
<input type="checkbox"/> Cursor.....	26
<input type="checkbox"/> Display.....	27
<input type="checkbox"/> Pan.....	27
<input type="checkbox"/> Peak Detect .....	28
• <b>Digital Mult-iMeter</b> .....	28
<input type="checkbox"/> AC Volts (  ).....	28
<input type="checkbox"/> DC Volts (  ).....	29
<input type="checkbox"/> mA(  ).....	32
<input type="checkbox"/> A(  ).....	33
<input type="checkbox"/> Frequency Counter .....	35
<input type="checkbox"/> Resistance(  ) .....	36
<input type="checkbox"/> Continuity(  ).....	37
<input type="checkbox"/> Diode (  ) .....	37
<input type="checkbox"/> Capacitance(  ).....	38
<input type="checkbox"/> AUX.....	39
<input type="checkbox"/> Power Efficiency .....	40
<input type="checkbox"/> Ripple Noise.....	41
• <b>Signal Out (  )</b> .....	41
• <b>Logic Analyzer</b> .....	43
<input type="checkbox"/> Measurement Procedure .....	44
<input type="checkbox"/> Trigger Menu Setting .....	45
<input type="checkbox"/> Cursor Menu Setting .....	46
<input type="checkbox"/> Pattern Mode .....	46
<input type="checkbox"/> Duration Mode .....	47
• <b>Protocol Analyzer</b> .....	49
<input type="checkbox"/> Measurement Procedure .....	50
<input type="checkbox"/> CAN.....	52
<input type="checkbox"/> LIN.....	53
<input type="checkbox"/> I2C .....	54
<input type="checkbox"/> UART .....	57

<input type="checkbox"/> USB .....	59
<input type="checkbox"/> I2S .....	62
<input type="checkbox"/> SM Bus .....	63
<input type="checkbox"/> SPI .....	64
<input type="checkbox"/> DMX 512.....	67
<input type="checkbox"/> I – Wire .....	69
<b>Pattern Generator .....</b>	<b>71</b>
<input type="checkbox"/> Signal Line and procedure .....	72
<input type="checkbox"/> UART.....	73
<input type="checkbox"/> CAN .....	75
<input type="checkbox"/> User Defined .....	77
<b>3. How to measure Subsidiary Function .....</b>	<b>79</b>
• Data Logger .....	80
• Data Saving .....	85
• Data Hold(Trigger Hold).....	86
• Auto Hold .....	87
• dBm (decibel measurement) .....	88
• Rel (Relative measurement) .....	88
• Peak Hold .....	89
• Limit .....	90
• Min/Max.....	90
• PC Interface(USB) .....	91
<b>4. Software Installation.....</b>	<b>93</b>
<b>5. Initial Settings before use.....</b>	<b>97</b>
• User Mode.....	97
• Initial set up setting options .....	98
• Battery Save .....	100
<b>6. Maintenance.....</b>	<b>101</b>
• General maintenance .....	101
• Battery Replacement .....	101
• Battery Charging .....	101
• Fuse replacement .....	101
• Trouble shooting .....	102
<b>7. Function Test and Calibration .....</b>	<b>103</b>
• Calibration concept .....	103
• Recommended Test Equipment .....	103
• Basic Performance Test .....	103
• Points to consider.....	103
• Calibration Points to review .....	104
• Calibration Procedure .....	104
<b>8. Specifications.....</b>	<b>105</b>
• Electrical Specifications.....	105
• General Specifications .....	112
• Environments.....	112

# 1. Introduction



## □ Major Functions



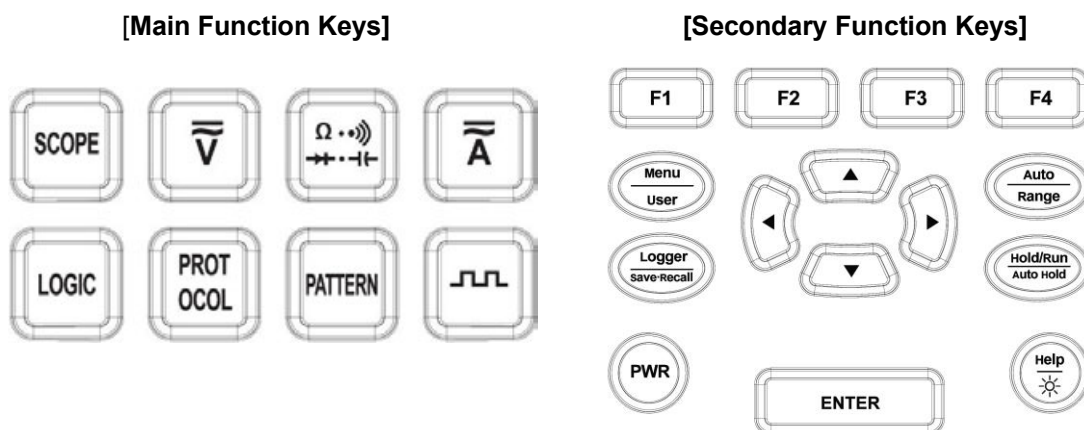

- 240\*160 pixel, 3.5" Graphic display.
- DC, AC, AC+DC Volts and Currents measurements.
- AC Volts and Current True RMS measurements.
- DC Volts
- AC Volts
- AC+DC Volts
- Resistance, Continuity, Capacitance, Diode measurements.
- Frequency Counter
- 10MHz Bandwidth 1channel Oscilloscope
- milliohm meter
- Current Source
- LED Analyzer
- Logic Analyzer
- Protocol Analyzer
- Pattern Generator
- Selectable Base Impedance to measure dBm.
- AUX function : Temperature, Pressure, High Currents, Humidity
- Frequency, Duty Cycle, Pulse Width
- MIN (minimum). MAX (maximum), AVE (Average), Present Measuring Value
- Data Logger
- Internal Charging System and Ni-MH Battery
- Battery Capacity Level Display
- GUI Application Software (USB)
- EN/IEC 61010-1:2001 Category III 600V Pollution Degree : 2

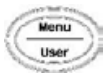







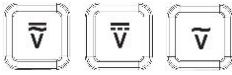

## □ Front View



**[Function Key Description]**

Function key	Description
	Selects Sub Menu functions and modes, for each Main Menu Mode.
	Upper Line: (Short Key) One Touch press Enter Menu (Main Menu) functions and modes. Lower Line: (Long key) Hold longer than 2 seconds to enter USER. Press Exit key to return to Main Menu.
	Upper Line : Meter setup Auto Ranging mode Lower Line : (Long key) Hold longer than 2 seconds to enter Manual measurement mode (Range)  - In Manual Range, range up/down can be done with Short key (One touch) press. - To return to Auto measurement mode, Hold key longer than 2 seconds
	Upper Line: (Short Key) One Touch press enter Data Logger mode. Lower Line: (Long key) Hold longer than 2 seconds to enter Save (Data) and Recall (Data) mode. Save or Recall mode selection is available in sub-menu.  - Press Short Key to change Logger Mode. - Press F4 Exit to leave Logger mode.

	Upper Line (Manual Hold): (Short Key) One touch press to enter Hold/Run mode. Holds the present measurement value on Display and can save the value. Changing from Hold to Run can be done (Short Key) One Touch press.  Lower Line (Automatic Hold): (Long key) Hold longer than 2 seconds to enter Auto Hold mode.
	I (Help): (Short Key) One Touch press enter Help mode. Brief Information on present function is displayed. Back Light On/Off: Hold longer than 2 seconds to enter Back Light display mode. Help: shot key(50ms), Backlight: long key(2s)
	Turn the meter power ON/OFF <b>HOLD</b> Longer than 2 seconds to power ON / OFF
	Cursor buttons select an item in Menu. Adjust Display Ratio. Scroll the information and Input the Data

	<p>All functions and menus on the rubber keys will be set automatically after 2 seconds after selection of functions or menu.</p> <p>Press ENTER key to set immediately after select of Functions or Menu to avoid the 2 second wait time.</p>
	<p>Volts measurement keys : AC+DC, DC, AC</p>
	<p>Currents measurement keys : AC+DC, DC, AC</p>
	<p>Resistance, Continuity, Diode key</p>
	<p>Capacitance measurement key</p>
	<p>Auxiliary measurements (Temperature, Relative Humidity, Hi-Currents. Pressure can be measured through external adapter)</p>
	<p>Square wave signal out put</p>
	<p>Oscilloscope</p>
	<p>Protocol Analyzer</p>
	<p>Pattern Generator</p>
	<p>Logic Analyzer</p>

## □ LCD Display

[Scope display symbols]



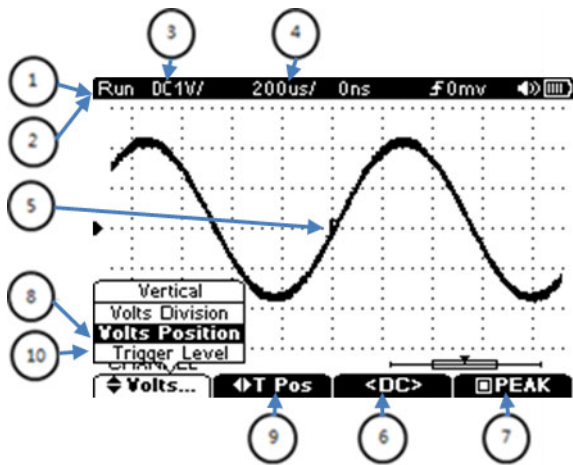





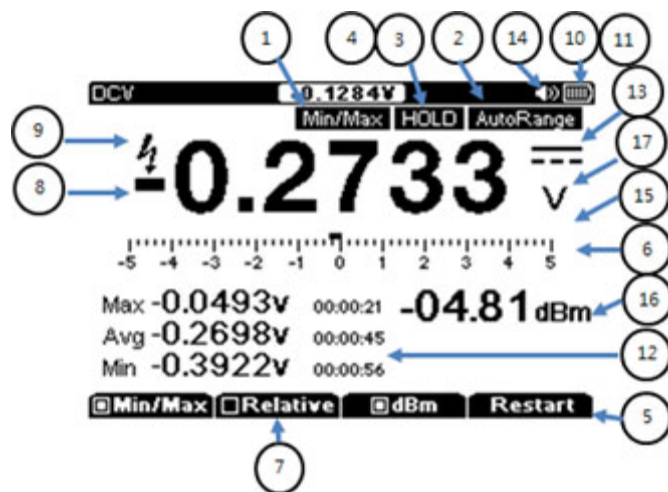









No	Symbol	Description
1	RUN	Presently measurement in proceeding and working.
2	HOLD	measurement is being stopped (holding) momentarily
3	V/div	Volt (Vertical Axis) Division indicator
4	T/div	Time (Horizontal Axis) Division indicator
5	Trigger	Trigger indicator for Level, Position or Edge direction
6	Coupling	Input Coupling selection (DC/AC)
7	Peak	Peak Detection selection (ON/OFF)
8	V/Position	Volt (Vertical Axis) Position adjustment
9	T/Position	Time (Horizontal Axis) Position adjustment
10	Trig Level	Trigger Level adjustment

### [DMM Display symbols]



No	symbol	Description
1	<b>Min/Max</b>	Minimum. Maximum, Average measurement
2	<b>AutoRange</b>	Can select Measuring Range in Automatic mode or Manual mode

3		Freeze the present reading in display.
4		Freeze the present reading in display.
5	Sub Menu 	The Sub Menu. After main menu selected, sub menu tree shows up to select options.
6	Bar-Graph 	Input Signal is displayed in Bar-Graph. see details on" Bar-Graph page )
7		Compare with the reference value and display the Difference.
8		Negative Reading
9		Over voltage on input warning (Voltage higher than defined safety protection voltage)
10		Remaining Battery Capacity level.
11		AC Power Adapter is connected.
12		Sampling, Run time
13		Measurement mode.(DCV, ACV, Ohm, Capacitance, Diode)
14		Audible signal is active
15	 (Bar Scale)	Range of Meter
16	Secondary measurement	secondary measurement information of Input Signal (Hz. dBm)
17		Unit symbol is displayed at right side of the measurement

**[Data Logger Display Symbol]**

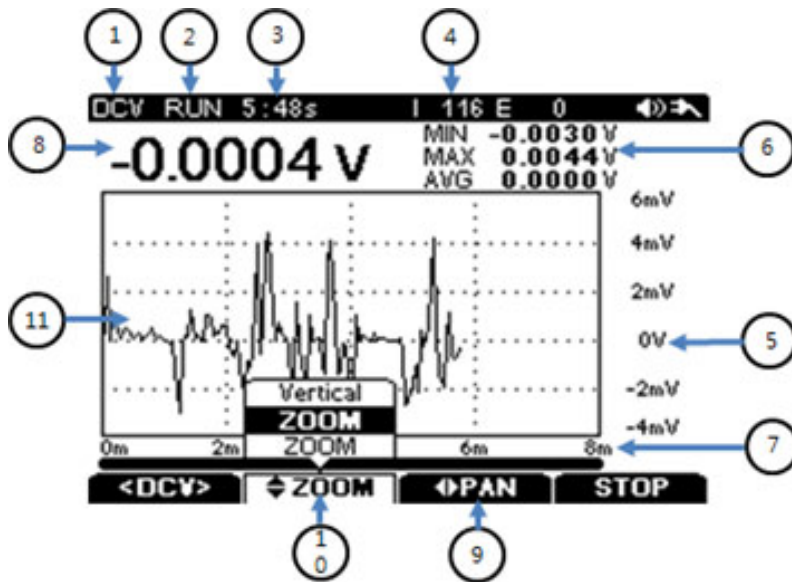

No	Symbol	Description
1	<b>DCV</b>	Measuring Mode. (DCV, ACV, Ohm, Capacitance, Diode)
2	<b>RUN</b>	RUN or STOP indication of Data Logging function
3	<b>5:48s</b>	Run Time
4	<b>116</b>	Accumulated Sample (Qty in Data Logger).
5	<b>6mV</b>	Maximum Display Range
6	MIN <b>-0.0030 V</b> MAX <b>0.0044 V</b> AVG <b>0.0000 V</b>	Minimum, Maximum , Average of the Samples
7	<b>8m</b>	Total Time Scale of Data Logging.
8	<b>-0.0004 V</b>	Present Measurement Value
9	<b>PAN</b>	Change the Time Scale (left - right horizontal axis) to review closely on the specific Time Zone.
10	<b>ZOOM</b>	Zoom (at Regular Ratio) the specific waveform quickly (up/ down Vertical axis).
11	Data Logger	Data Logger Display

**[Logic Analyzer Display Symbols]**

**[Protocol Analyzer Display Symbols]**

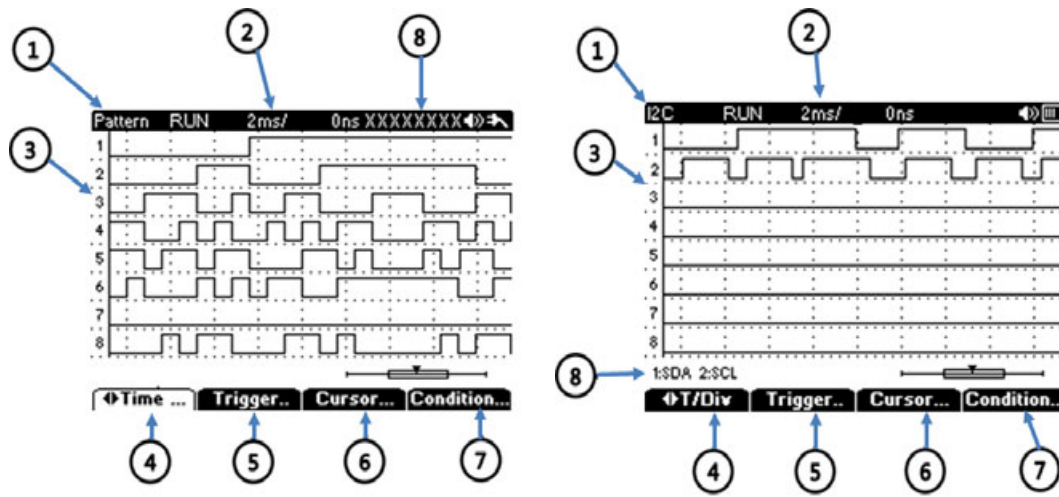

[Logic Analyzer, Protocol Analyzer Display Symbol]

No	Symbol	Description
1	Condition	Logic Analyzer: Pattern, Duration Protocol Analyzer: CAN, LIN, I2C, UART, USB, I2S SMBus, SPI, DMX512, 1-Wire
2	Time/div	Measurement Time/div Indicator
3	Channels	Displays all the Input Channels
4	Horizontal	Time Division & Position adjustment
5	Trigger	Trigger Mode, Source, and Trigger Level adjustment
6	Cursor	Horizontal Cursor adjustment
7	Condition	Detailed condition setting for each Logic or Protocol type
8	Information	Display window to show the trigger condition or channel input information of each type

[Pattern Generator Display Symbol]

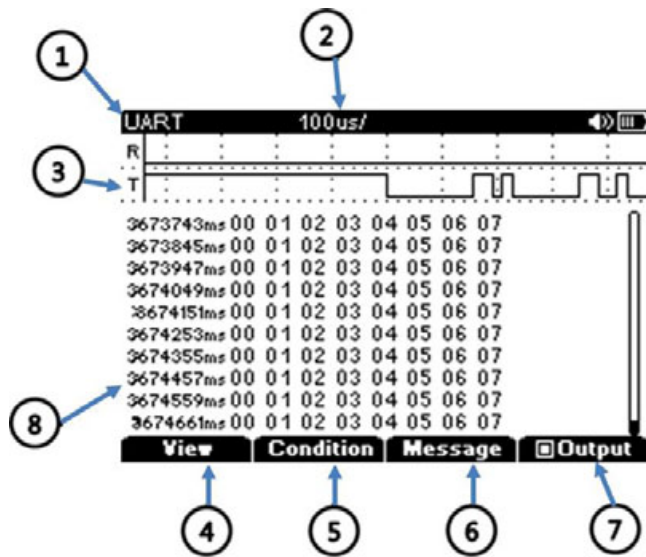

No	Symbol	Description
1	Condition	UART, CAN, (User Definable)
2	Time/div	Measurement Time/div Indicator
3	Channels	Displays all Channels (TX/RX)
4	View	Selection of Transaction/Message, Acquisition Mode, and Cursor adjustment
5	Condition	Selection of Trigger condition, Trigger Level, and Baud rate used to decide the speed of pattern
6	Message	Used for making the format, cycle, and data of each pattern
7	Output	Selection of signal out or not
8	Information	Display window to show the information of In/Out Transaction or all the memorized messages

#### [BAR-GRAPH]

- BAR-GRAPH displays Measurement Data in an Analogue Meter Display type. Refresh rate is 15 times / second. Response Time of Analogue display is faster than Digital display which Bar -Graph display is very efficient to observe display like as PEAK that input change very fast.
- Pattern Generator, Current Generator, logic Analyzer, and MIN/MAX modes do not activate the BAR-GRAPH display.
- Direct Voltage, Currents and Relative displays the BAR-GRAPH "0" in the center position. For Direct Voltages and Currents, the BAR-GRAPH total scale displays the Maximum of

the selected measurement range.

- Displayed Segment indicates Measurement Size which is displayed within the Maximum Scale of selected range.
- When measured value exceeds the maximum scale of the selected range, ► is displayed at RIGHT of BAR-GRAPH. When Direct Voltage or Current, ◀ is displayed at LEFT of BAR-GRAPH at negative MAX and ► is displayed at RIGHT of BAR-GRAPH at positive MAX

**[Measurement Status display]**

- Status icons are shown at the top of Display.
- Battery status, Present Measurement Value, Buzzer (Continuity), Data Hold, Auto Hold, AC Power Adapter Connected.

**[Display]**

- Display consist of Main Measurement Display, BAR-GRAPH display, Sub function display (Sub measurement or Data)

**[Sub Menu Keys]**

- 4 keys (F1 ~ F4) underneath the Display. Select sub-menu functions dependent upon measurement mode function or menu

**□ Measurement Input Terminals**

**[Front Case Input]**

To prevent Damage, Do not apply signals that exceed the ratings for the input channels.

**Input Terminal Connection**

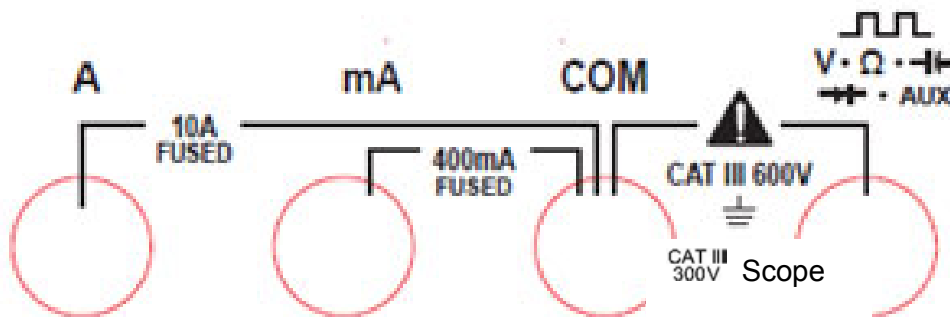

Measurement	Input Terminal
10A	0 A ~ 10.00 A currents. (10A overload, 30sec On, 10 sec OFF)
mA	0 A ~ 500 mA Currents measurement.
COM	Negative Terminal to all measurements.
SCOPE, V, Ω, Hz, , AUX	Volts, Continuity, Resistance, Diode, Capacitance, Frequency measurement and AUX (auxiliary function with external adapter : Temperature, High Current, Relative Humidity, Pressure measurement)
13 pin socket Terminal	13 pin socket Terminal (Measurement and Output) : Logic Analyzer, Pattern Generator, Protocol Analyzer. Sig. Out

**[Logic Cable Input]**

13 Pin Logic Cable - used for Logic Analyzer, Protocol Analyzer, Pattern Generator, and Signal Out generator.

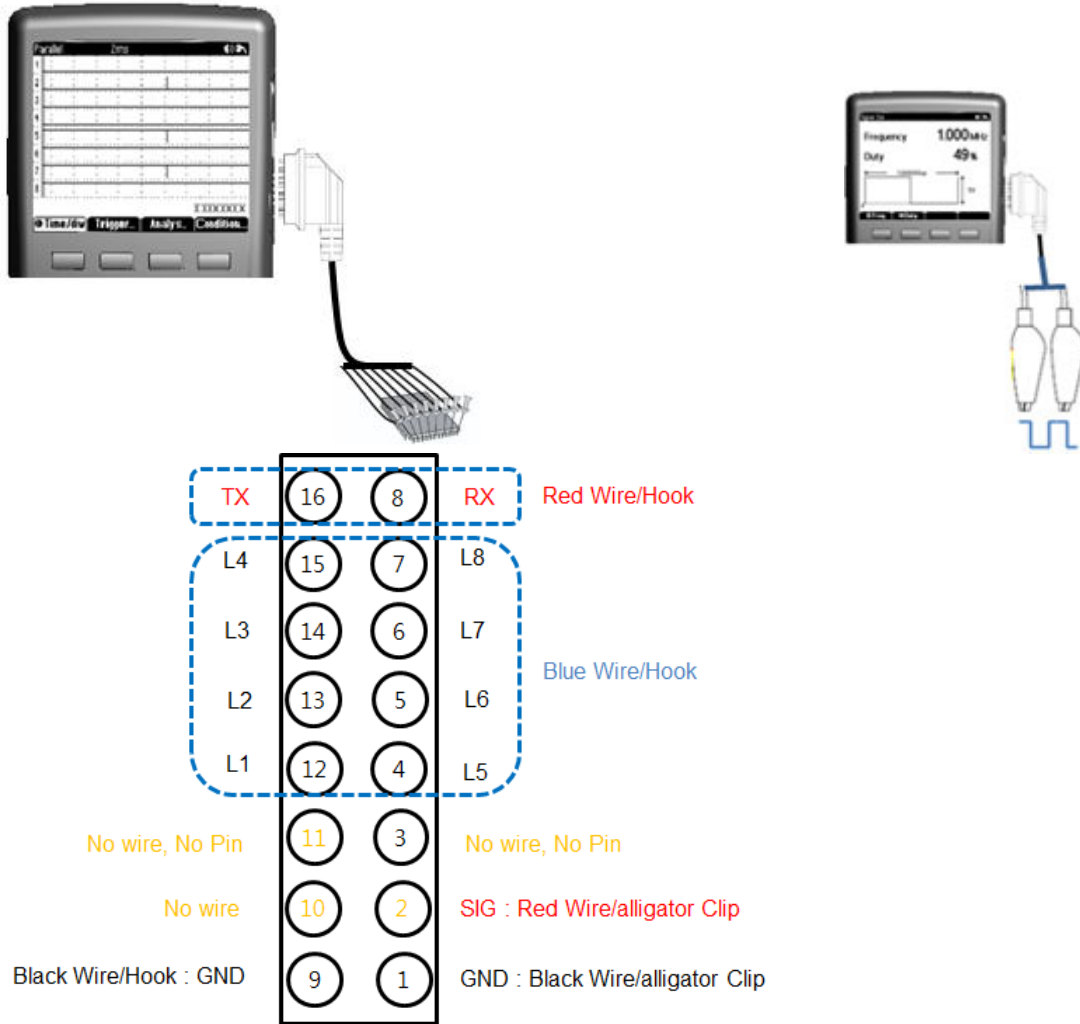

Pin No	Function	Pin No	Function
1	Ground(Black/Clip)	9	Ground(Black/Hook)
2	Signal out(Red/Clip)	10	N/A
3	N/A(pin cutting)	11	N/A(pin cutting)
4	Logic5(Blue/Hook)	12	Logic1(Blue/Hook)
5	Logic6(Blue/Hook)	13	Logic2(Blue/Hook)
6	Logic7(Blue/Hook)	14	Logic3(Blue/Hook)
7	Logic8(Blue/Hook)	15	Logic4(Blue/Hook)
8	Pattern Generator RX(Red/Hook)	16	Pattern Generator TX(Red/Hook)

## □ Rear View and Side View



## □ Voltage Warning

- User should pay attention to the Voltage Ratings and Over Voltage warnings.
- Immediately remove the Test Leads/Test Probes from the circuit if the VOLTAGE WARNING comes on the screen. Scope function Input (SBS- 700), has a max 300V. Other Multi-meter function Inputs (SBS-600 and SBS-700), max 600V. Milliohm Meter- meter input (SBS-6500). Max 50VDC.
- Meter will display the VOLTAGE WARNING regardless of AUTO or MANUAL measurement mode. When over the Maximum Measurement limit, the WARNING alert sound starts. In this case, immediately remove Test Leads/Test Probes from the circuit under test
- When measurement range is set to manual. The display shows “OL” if the range is exceeded.





## □ Power

- Re-chargeable 7.2V NiMH Battery Pack or AC Power Adapter.



#### □ Remaining Battery Capacity Level indicator

- Top right display indicates Remaining Battery Capacity Level,

Level	Remaining Battery
	Fully Charged.
	3/4 charged (75 %)
	1/2 charged (50 %)
	1/4 charged (25 %)
	Recharge Battery (0 %) / use AC Adapter

#### □ Auto Power Off

- While in operation, the meter will automatically power off after 15 minutes with no key press on any key.
- User can select the Auto Power Off time (min 5 minutes ~ max 2 hours or Auto Power Off mode) in the User Menu.

#### [NOTE]

- Auto Power Off mode does not activate in DATA LOGGER mode (MIN MAX, PEAK mode in operation)
- Auto Power Off mode does not activate when Meter is powered by ADC Power Adaptor.



#### □ Battery Saver Mode

- Auto Power Off mode is not activated when in Data Logger or Auto Hold mode of operation. If no key is pressed on Meter for the set amount of time, the Meter automatically changes to Battery Saver Mode. Mode enable time is equal to Auto Power Off mode timing.
- All features including Display will power off except for the present active measurement function.
- Release Battery Saver Mode by:
  - Pressing any key
  - Change the measurement range
  - Start PC Interface communication.Meter function and Operation Mode does not change when exiting battery saver mode.



#### □ Back Light Display

- When measurement environment is dark or it is hard to see the LCD display, HOLD the Back Light key  longer than 2 seconds.
- Back Light operation time can be set in the USER MENU (Off Mode, Min 1 minutes ~ Max 1 hour).

#### □ Measurement Range selection (Auto/Range)

- Selected Measurement Range is shown to the Right of the BAR-GRAPH. The  key, changes between AUTO Range mode or Manual Range mode. Pressing the  key in MANUAL Range mode will automatically shift the meter back to AUTO Range.

[NOTE]

-  Key is not active during Capacitance, Diode, or Frequency modes which are always set automatically Auto Ranging.
- Manual Range mode can be switched to Auto Range mode by holding the  key longer than 2 sec.
- Auto Range mode can be switched to Manual Range mode by holding the  key longer than 2 sec.
- In manual mode, the Up/Down keys will move the decimal point for the range.

□ MENU

- After “Scope”(DSO) function is selected, press  MAIN Menu to select the Channel, Trigger, Measure, Cursor
- After Main Menu selected, enter Sub Menu F1, F2, F3, F4 to proceed to the desired measurement..

[Sub Menu]

From the Sub Menu (Channel, Trigger, Measure, Cursor), another Sub menu appears for each of the Sub Menu items.

[Oscilloscope Sub Menu]

DSO (Channel)	F1	F2	F3	F4
	Vertical	Horizontal	Coupling	Peak
DSO (Trigger)	F1	F2	F3	F4
	Type	Slope	Mode	
DSO (Measure)	F1	F2	F3	F4
	Measure1	Measure2	Measure3	Measure4
DSO (Cursor)	F1	F2	F3	F4
	Cursor(on)	Mode X	Mode Y	

**[Multi-meter Sub Menu]**

**<Volts>**

DMM (Vdc)	F1	F2	F3	F4
	Min/Max	<input checked="" type="checkbox"/> Relative		Stop
	Peak			

Vac	F1	F2	F3	F4
	Min/Max	<input checked="" type="checkbox"/> Relative	dBm	Stop
	Peak		Filter	

DMM (Vac+dc)	F1	F2	F3	F4
	Min/Max	<input checked="" type="checkbox"/> Relative		Stop
	Peak			

AUX	F1	F2	F3	F4
	Min/Max	<input checked="" type="checkbox"/> Relative	Temp	Stop
	Peak		Ampere Humidity  Pressure	

**< Resistance, Diode, Capacitance>**

DMM (ohm)	F1	F2	F3	F4
	Min/Max	Relative	Limit	

DMM (Continuity)	F1	F2	F3	F4
			Limit	

DMM (Diode)	F1	F2	F3	F4
			Limit	

DMM (Capacitance)	F1	F2	F3	F4
	Min/Max	Relative	Limit	

**< Currents >**

DMM ( $\mu$ A)	F1	F2	F3	F4
	Min/Max	Relative	dBm	AC

DMM (mA)	F1	F2	F3	F4
	Min/Max	Relative	dBm	AC

DMM (10A)	F1	F2	F3	F4
	Min/Max	Relative	dBm	AC

### [Logic Analyzer Sub Menu]

#### - Pattern, Duration

Main Menu	F1	F2	F3	F4
	Horizontal	Trigger	Cursor	Condition

### [Protocol Analyzer Sub Menu]

- CAN, LIN, I2C, UART, USB, I2S, SMBus, SPI, DMX512, 1wire
- All Protocol type has same Sub Main Menu condition is same as below

Main Menu	F1	F2	F3	F4
	Horizontal	Trigger	Cursor	Condition



### [Pattern Generator]

- UART, CAN, User
- All Protocol type has same Sub Main Menu condition is same as below



Main Menu	F1	F2	F3	F4
	View	Condition	Message	Output



Above Menus shows Initial Set Up status. When a function or mode is selected by pushing the function key on a Sub Menu (F1~F4), the selected function or mode is activated instantly, and then the POP UP window is shut off and the selected menu is displayed on screen.

### □ Help

- While the Meter is in operation, pressing the  key longer than 1 second will display brief information or an explanation about the present function or mode.
- Press the  key longer than 1 second to exit Help mode.
- Help mode contains brief information from the Users Manual for quick reference.
- Where Help information is more than 1 page of the screen, you can scroll the contents with Cursor (Up/down) keys.

### □ Data Hold/Auto Hold

- In order to momentarily hold the measurement value on the screen, press  HOLD key. The measurement value is displayed in Hold mode, but the meter is actually still acquiring measurement data. Pressing the  key once more will release HOLD mode.
- Pressing  for more than 1 second will enter **Auto Hold** mode. When in Auto Hold mode, the monitoring and display of the input signal is continuously updated.
- Whenever a new measurement is acquired during Input the display is updated and the alert signal sounds.

- Auto Hold can be reset by pressing the  key.
- Hold the  key for longer than 2 seconds to release Auto Hold.

**SAVE / RECALL**

- Saves the Waveform or the Data on the display. Data is saved to the internal memory of the meter and can be recalled and displayed on meter the meter or in the software.
- Hold the  key longer than 1 second.
- Use Sub Menu keys to Save, Recall or Erase

## 2. How to Measure Main Functions

- Oscilloscope
- Digital Multi-meter
  - AC Volts
  - DC Volts
  - $\mu\text{A}/\text{mA}$
  - 10A
  - Frequency Counter
  - Resistance, Continuity
  - Diodes
  - Capacitance
  - Power Efficiency measurement
  - Ripple measurement
  - Aux measurement
- Sig .Out
- Logic Analyzer
- Protocol Analyzer
- Pattern Generator

**Digital Oscilloscope Measurement**

Waveform acquisition and Analysis can be achieved by simple operation using the general test leads. Automatic scale and setup feature with single press of  key.

- Real Sampling : 50MS/s
- Bandwidth: 10MHz
- CH : 1
- V/div: 20mV ~ 100V
- T/div: 100ns ~ 50s
- Test Probe : Test Leads for multi-meter or Oscilloscope probe (1:1)

[How to measure]

- Insert test leads into the meter as shown below in the picture. Black Test Lead inserts to COM(-) Input Terminal and Red Test Lead inserts to SCOPE(+) Input Terminal
- Press the  main function key

- Press Menu  key and select Channel, Trigger, Measure or Cursor. Set to desired settings.
- Start measurement

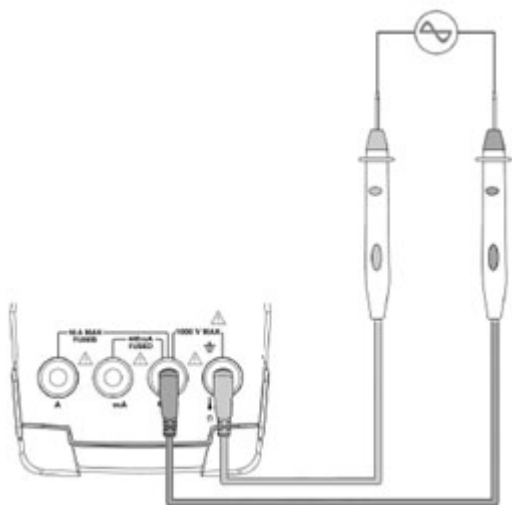

[NOTE]

- The below SUB Menu shows up after selecting the Main Menu (Channel etc.), use the Cursor  keys located in the middle of Meter to make adjustments.
- Upper Line of Display shows Run/Hold, V/div, T/div, trigger Slope values for Oscilloscope measurement.

### 1) Channel Menu

This function is to adjust the display of the best waveform viewing by adjusting waveform vertical axis (Amplitude) or horizontal axis (Time). There are Vertical, Horizontal, Coupling and Peak adjustments.

Channel	F1	F2	F3	F4
	Vertical	Horizontal	Coupling	Peak
	▲▼V div	T div	DC	
	▲▼V pos	H pos	AC	
	▲▼Tr level			

[Vertical] : F1 (  )

Adjust the amplitude of signal for the best waveform display.

Can adjust **Voltage div (V div)**, **Vertical Position (V pos)**, **Trigger Level (Tr Level)**

- After selection menu, use the Cursor ▲▼ keys to adjust position or sensitivity.
- Adjusted value will be updated once key is pressed. Holding the key longer than 2 seconds, will scroll the setting. Update setting stops if the key is released.
- V/div** is used to adjust Vertical Sensitivity. Range can be adjusted from 20mV ~ 100V
- V pos** (Vertical position) is to adjust of Waveform position on the (Vertical Axis). Adjustment is available from minimum value to maximum value of Scale : 6 divisions

- **Tr level** (Trigger Level) is also to use to adjust of Waveform position (Vertical Axis). Adjustment is available from minimum value to maximum value of Scale: 6 Division. It sets Tr Level for Signal Acquisition by comparing the Trigger Source. Present level voltage and position mark shown on display. The level can be adjusted by the Cursor ▲ ▼ keys.

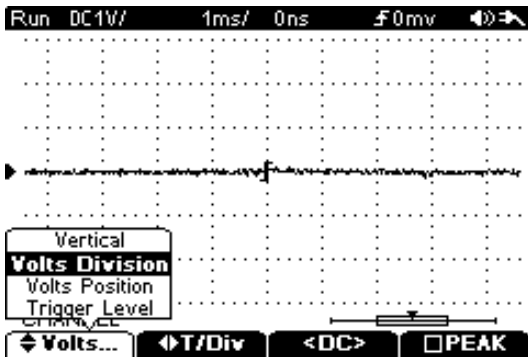

[F1 Vertical]

### [Horizontal] : F2 ( )

Adjusts the time period of the displayed signal to view the best waveform display.

Can adjust **Time div(T div)**, **Time Position(T pos)**

- After selection menu, use Cursor ◀ ▶ keys to adjust the position
- Adjusted Position is changed once per key press. If the key is held longer than 2 seconds, the adjusted position scrolls to the desired value. Update stops if key is released.
- **T/div** is to adjust the Horizontal Sensitivity. Adjustment Range is: 100ns ~ 50s
- **T pos** (Time position) adjust the Waveform position on the (Horizontal Axis). Adjustment is available max 20 div to left direction or to right direction. Position information shows on lower right area of display.  The center black thick bar indicates the Position Change area

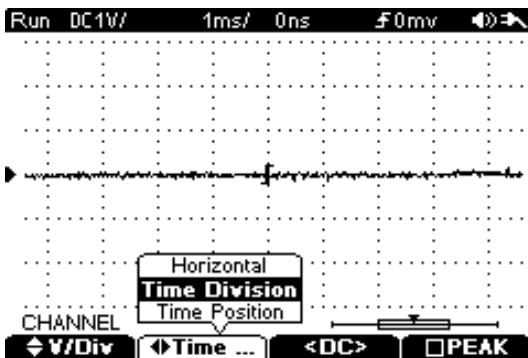

[F2 Horizontal]

### [Coupling]: F3 ( )

To measure specific characteristics of the Waveform, Selectable to either:

#### **DC coupling or AC Coupling**

- DC Coupling: can observe all characteristics of the input signal connected. Shows **DC**.
- AC Coupling: can observe AC characteristics of the input signal connected. Shows **AC**.

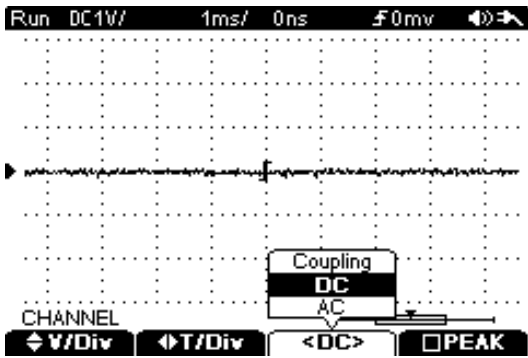

[F3 Coupling]

## 2) TRIGGER

Used to adjust the starting point of the trigger for the signal to be displayed.

Select Trigger in Main Menu and adjust Trigger type and setting Values. Will capture Rising or Falling Edge of Trigger Level and trigger Settings Values are displayed. Basic Menu consists of F1 (Type), F2 (Slope) F3 (Mode). Detailed operation procedure of respective functions is as follows;

Trigger	F1	F2	F3	F4
	Type	Slope	Mode	
	Edge	Rising	Auto	
	Pulse	Falling	Normal	
		Alternate	Single	
		Either		

### [Edge Trigger]

- Press F1 (Type) and select Edge.
- F2 Select Trigger Slope among Rising, Falling, Alternate, Either
- F3 Select Trigger Mode among Auto, Normal, Single.

Mode: select Trigger Mode first.

- Auto, Normal, Single: select Auto Mode and Manual Mode.

Slope : Select Slope

- Rising, Falling, Alternate, Either.

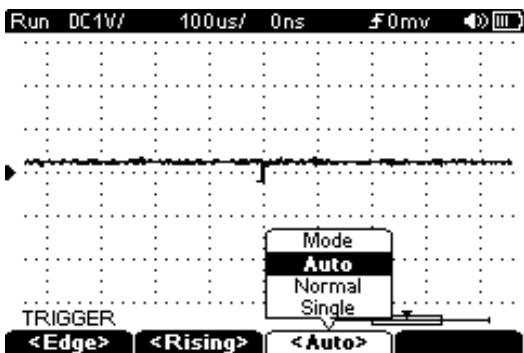

### [Pulse Trigger]

- Press F1 key to select Pulse Trigger type.
- Press F2 key and select Slope type. Positive or Negative
- Press F3 key and select among Auto, Normal, or Single.
- Press F4 and set Qualifier(Less, Greater, in, out)



Pulse	Slope	Mode	More Setting...
	Positive Negative	Auto Normal Single	

- Slope : select Slope
  - o Positive, Negative
- Mode: select Trigger Mode first.
  - o Auto, Normal, Single
- Setting (Qualifier)
  - o Less, Greater, IN, OUT
- Setting (Time): range 50ns~10.00s and adjust by 10ns step.

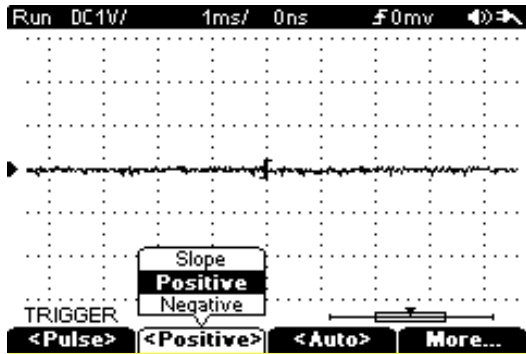

### 3) MEASURE

Use this function to select various value information about the currently displayed waveform. The values for the items listed below can be displayed. Display will show real time signal waveform and values for the selected measurements to the right of the waveform.

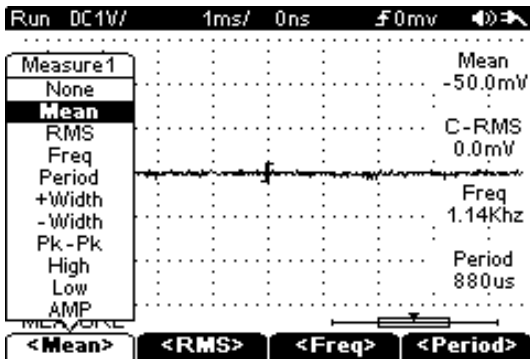

- All single shot measurements: A max of 4 values can be shown on the right side of display.
- Measure Value: select among OFF, Mean, RMS, Frequency, Period, +width, -Width, Pk-Pk, Hi, Low, Amp.
- Selected Measure menu are shown in F1~F4 Sub Menu.
- Settings are retained in memory until they are manually changed and will remain set even when the unit is powered off.

Measure	F1	F2	F3	F4
	Measure1	Measure2	Measure3	Measure4
	Off	Off	Off	Off
	Mean	Mean	Mean	Mean
	RMS	RMS	RMS	RMS
	Freq	Freq	Freq	Freq
	Period	Period	Period	Period
	+Width	+Width	+Width	+Width
	- Width	- Width	- Width	- Width
	Pk-Pk	Pk-Pk	Pk-Pk	Pk-Pk
	Hi	Hi	Hi	Hi
	Low	Low	Low	Low
	AMP	AMP	AMP	AMP



#### 4) CURSOR: Scope Main Menu

User can adjust the waveform vertical axis (Amplitude) and horizontal axis (Time) to the desired point for observation on the display. Cursor keys will move Waveform Left/Right, and/or, Up/Down.

- Press the "SCOPE"  key. Press the Menu  key and select CURSOR in the Left Column of the Menu.
- After CURSOR is selected, press "F1" and "ON".
- Use the Cursor key "F2" mode Y (Amplitude, Volts) or "F3" mode X (Time) of waveform.
- After the mode is selected, move the waveform to desired location with Cursor Keys.

Cursor	F1	F2	F3	F4
	Cursor	Mode X	Mode Y	(Blank)
OFF		◀▶X1	▲▼Y1	
ON		◀▶X2	▲▼Y2	
		◀▶X1X2	▲▼Y1Y2	

[Y cursor]

To measure voltage at the desired location. Cursor displayed in parallel with the Horizontal Axis and  $\Delta Y$  value is displayed in the lower area of the screen.

[X cursor]

To measure time at the desired location. Cursor displayed in parallel with Vertical Axis and  $\Delta X$  value is displayed in the lower area of the screen.

[Y1, Y2, X1, X2]

Need to select cursors as they apply to the actual measurement conditions.

- X1, X2, Y1, Y2
    - o X1: Left direction Cursor, X2: Right direction cursor
    - o Y1: Upper direction Cursor, Y2: Down direction cursor.
- Selected Cursor only move toward the direction.

Y1Y2 or X1X2:

Single cursors do not work independently. Two Cursors (either Horizontal or Vertical) can work together simultaneously. The interval of the cursors need to be equal, When observe characteristics of each block on Repeated signal with same interval, adjust the cursor width to Block and set Trace Mode and observe waveform by moving Cursor Select Trace Mode. This is a very convenient and efficient mode,

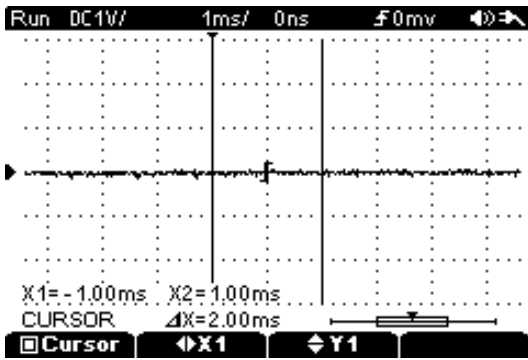

### 5) Display

- Adjustable to display the Acquired Signal or Other Waveform display environment

#### [Waveform]

- The Waveform is linked data points in line on the display.
- Horizontal 9 div x 25 = 225 data points.
- Vertical 6 div x25 = 150 data points.

#### [Contrast]

- Set in Users Menu to control the brightness of the display.
- Setting the value to a higher number will brighten the display.
- Adjustable level : 1 ~ 10

### 6) PAN

Allows the displayed signal waveform to be viewed in an expanded scale. Can adjust the Horizontal (time) axis as desired. Use Cursor keys (left or right) to select the desired block.

There are 2 methods to observe the Signal waveform in PAN mode.

- 1) Pan operation on presently active measured signal waveform.
- 2) Recall a Waveform stored from the internal memory of the meter.

- During Scope mode of operation, press “F2” (H pos) key in menu to enter Pan function

Channel	F1	F2	F3	F4
	Vertical	Horizontal	Coupling	Peak
	▲▼V div	◀▶T div	DC	
	▲▼V pos	◀▶H pos	AC	
	▲▼Tr level			

- Use the  directional keys to review the desired waveform.

- To review a saved signal waveform from memory, press the “Save/Recall”  key, and select “F3” (Recall) Key, then Pan Mode can be displayed and operate the Pan function with the Left-Right directional keys.

Save/Recall	F1	F2	F3	F4
(Scope)	<Trace>	▲▼Slot1	Recall	Save

Recall	F1	F2	F3	F4
(Scope)	◀▶H pos			Clear

## 7) Peak Detect

Allows the user to check signals for transients that occur over the duration of time in a signal. Also allows the user to check for harmonic or phantom signals superimposed on the source signal.

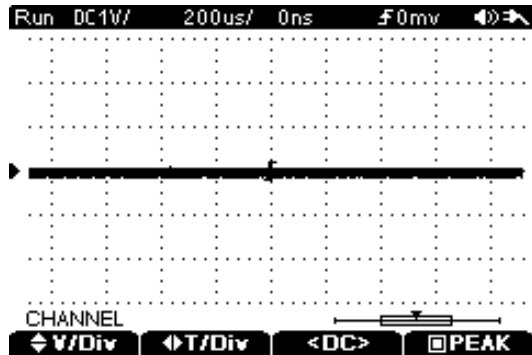



## Digital Multi Meter measurement

### AC Voltage measurement

Meter is capable of accurate RMS measurement readings of various AC signals. True RMS measurement is available for Sign, Square, Triangle waveforms, as well as other types of signals.

Voltage	F1	F2	F3	F4
	Min/Max	<input checked="" type="checkbox"/> Relative	<input checked="" type="checkbox"/> dBm	
	Peak			
	OFF			

- Press the  main function key.
- Next press the  Menu key and select "VAC" among VAC, VDC, VAC+DC,
- Insert Black (-) Test Lead to COM input terminal and insert Red (+) Test Lead into "V" input terminal
- Start measurement

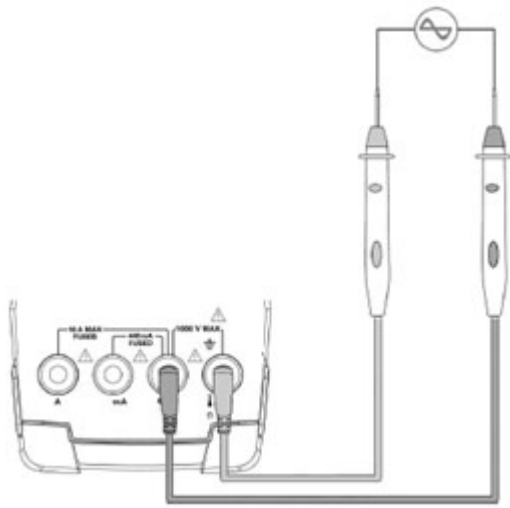

**[AC Voltage Measurement]**

- Measurement Range can be selected by Auto Range or Manual Range..
  - Auto Ranging Scales: : 5V, 50V, 500V, 600V (4 ranges)
  - Manual Ranging Scales: : 50mV, 500mV, 5V, 50V, 500V, 600V (6 ranges)
- The measured **Voltage** value is displayed on the main display and lower the area will display **Frequency** and **Duty** cycle values.
- Bar-Graph changes depending on the level of the value from the “0” point.
- The Sub Menu allows for: **Min/Max, Relative, dBm** measurements.

**[Safety Note]**

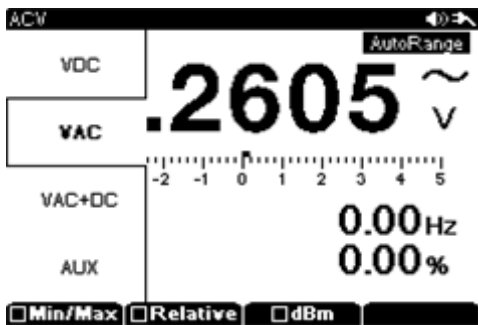

Before measurement, ensure the Test Leads/Probes are correctly inserted into the correct Input terminals. For safety, do not test circuits that exceed the Voltage Ratings marked on the meter.



**DC Voltage Measurement**

The Bar-Graph of the Display starts from the “0” point. Negative (-) voltage is displayed to the left of Center “0”. Positive (+) voltage is displayed to the right of Center “0”.

Voltage	F1	F2	F3	F4
	Min/Max	<input checked="" type="checkbox"/> Relative	<input checked="" type="checkbox"/> dBm	
	Peak			
	OFF			

- Press the  main function key.
- Next press the  Menu key and select “VDC” among VAC, VDC, VAC+DC
- Insert Black (-)Test Lead to COM input terminal and insert Red (+)Test Lead into “V” input terminal
- Start measurement

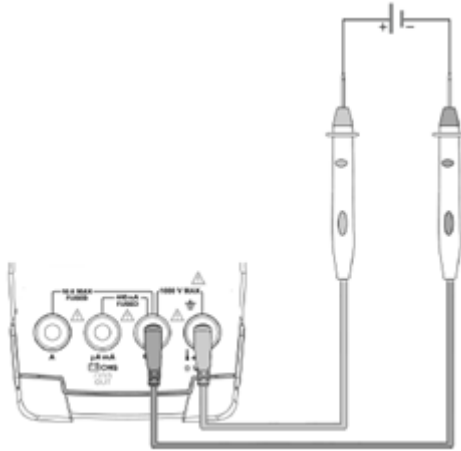

**[DC Voltage Measurement]**

- Measurement Range can be selected by Auto Range or Manual Range..
  - Auto Ranging Scales: : 5V, 50V, 500V, 600V (4 ranges)
  - Manual Ranging Scales: : 50mV, 500mV, 5V, 50V, 500V, 600V (6 ranges)
  - The measured **Voltage** value is displayed on the main display with polarity indication.
  - Bar-Graph changes depending on the level of the value from the “0” point.
  - The Sub Menu allows for: **Min/Max, Relative**, measurements.

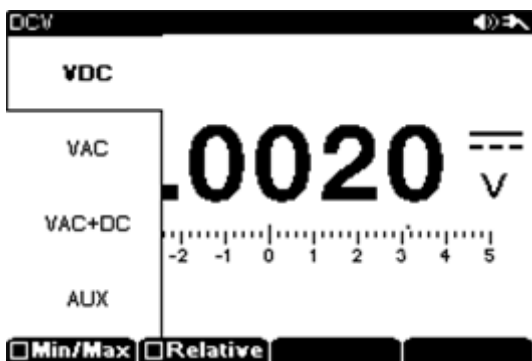

## □ AC+DC Voltage Measurement

The Meter measures the combined value AC+DC Voltage measurement, Measurement value displayed is the (Absolute Value). Bar-Graph will display in the Positive (+) direction only.

Voltage (AC+DC)	F1	F2	F3	F4
	Min/Max	<input checked="" type="checkbox"/> Relative		
	Peak			
	OFF			

□ Press the  main function key.

□ Next press the  Menu key and select "**VAC+DC**" among VAC, VDC, VAC+DC

□ Insert Black (-) Test Lead to COM input terminal and insert Red (+) Test Lead into "V" input terminal

□ Start measurement

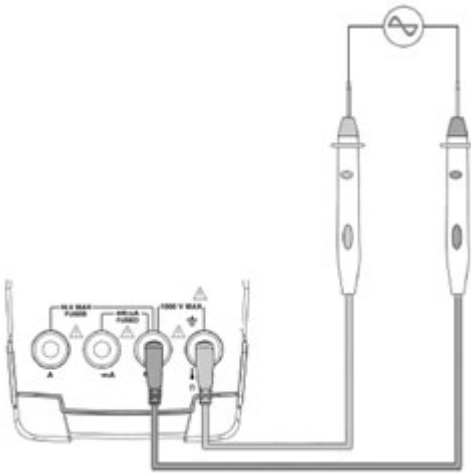

### [AC+DC Voltage]

□ Measurement Range can be selected for Auto Range or Manual Range.

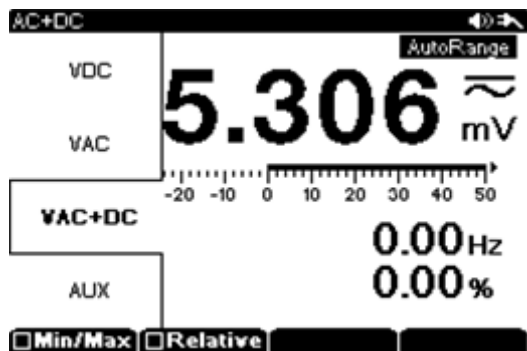

- Auto Ranging Scales: : 5V, 50V, 500V, 600V (4 ranges)
- Manual Ranging Scales: : 50mV, 500mV, 5V, 50V, 500V, 600V (6 ranges)
- The measured **Voltage** value is displayed on the main display with polarity indication.
- Bar-Graph changes depending on the level of the value from the "0" point.
- The Sub Menu allows for: **Min/Max**, **Relative**, measurements.



**□ Current Measurement (mA,  $\mu$ A) (500 milli-AMP MAXIMUM inline current measurement)**

Current measurements must be done with the circuit open and the meter connected in series as part of the circuit.

mA, $\mu$ A	F1	F2	F3	F4
	Min/Max	■Relative	■dBm	DC
	Peak			
	OFF			

- Press the  main function key.
- Next press the  Menu key and select m-Amp or  $\mu$ -Amp range
- Insert Black (-) Test Lead to COM input terminal and insert Red (+) Test Lead into mA input terminal.
- Start measurement

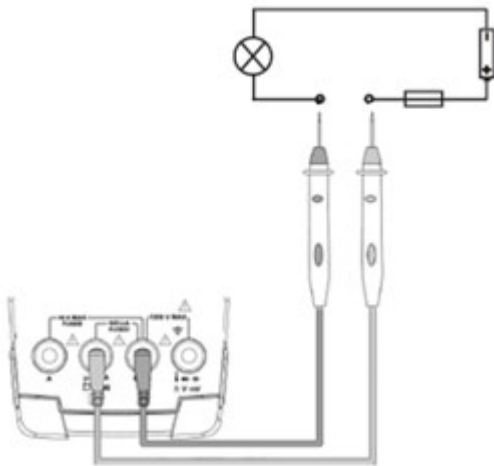

**[mA,  $\mu$ A measurement]**

- Measurement Range can be selected for Auto Range or Manual Range.
  - $\mu$ A: 500 $\mu$ A, 5mA(auto ranging)
  - mA: 50mA, 500mA(auto ranging)
- The measured Current value is displayed on the main display and the lower portion of the display will show Frequency and Duty (in AC Only)
- Protection: 500mA/250V Fuse
- The Sub Menu allows for: : Min/Max, Relative, dBm, DC, AC, DC+AC



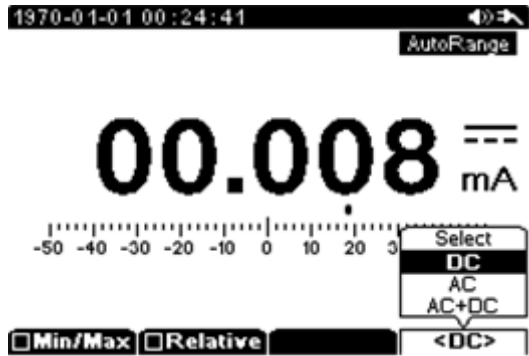
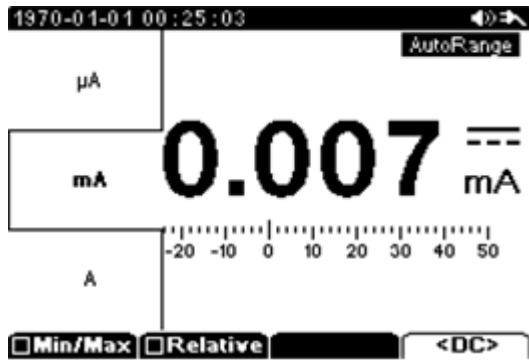

[Warning]

- To prevent damage to the meter or equipment being measured, check the FUSE before current measurements are made.
- Verify the correct Input Terminals and Measurement Range is set.
- When Leads are connected for Current Input Terminals, do not connect other Circuits or Components in Parallel.

**10A measurement (10 AMP MAXIMUM inline current measurement)**

Current measurements must be done with the circuit open and the meter connected in series as part of the circuit.

10A	F1	F2	F3	F4
	Min/Max	<input checked="" type="checkbox"/> Relative	<input checked="" type="checkbox"/> dBm	DC
	Peak			
	OFF			

- Press the main function key.
- Next press the Menu key and select A
- Press F4 key to select "DC, AC, AC+DC"
- Insert Black (-) Test Lead to COM input terminal and insert Red (+) Test Lead into 10A input terminal
- Start measurement

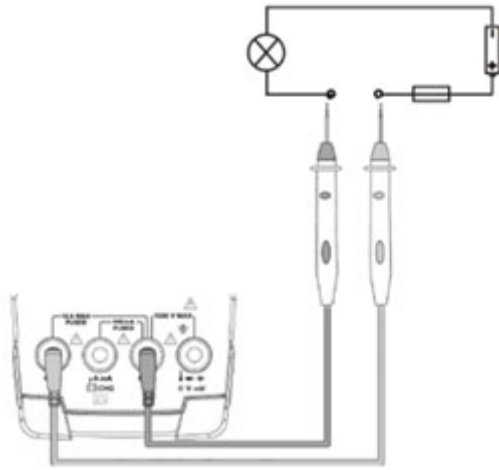

### [10A measurement]

- Measurement Range
- A : 10A max (1 range)
- The measured current value is displayed on the Main display, and Frequency, Duty value is displayed in sub display (AC current measurement only).
- Selectable sub menu: Min/Max, Relative, dBm, DC, AC, DC+AC
- Circuit Protection : 10A/250V Fuse
- Input current can not exceed 10 Amps. Measurement time must not exceed 30 Seconds.
- Allow a 1 minute cool down period before the next full current measurement to prevent overheating / damage to the meter.

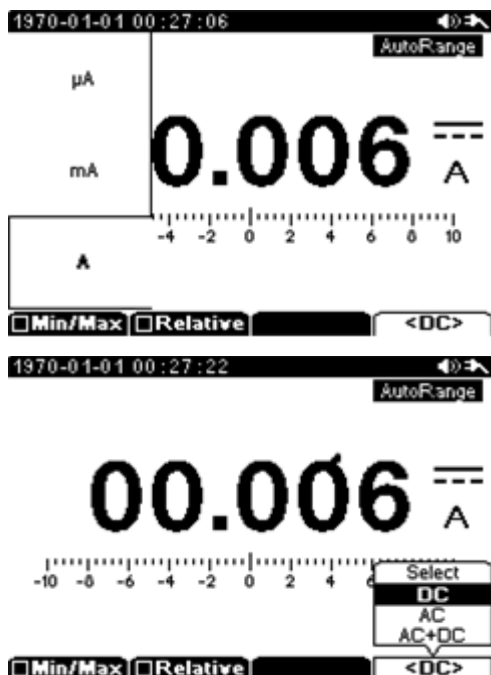



### [WARNING]

- To prevent damage to the meter or equipment being measured, check the FUSE before current measurements are made.
- Verify the correct Input Terminals and Measurement Range is set.
- When Leads are connected for Current Input Terminals, do not connect other Circuits or Components in Parallel.

## □ Frequency Measurement

Frequency measurements are displayed any time you are measuring AC Voltage or Current

- ① Press the  or  main function key.
- ② Next press the  Menu key and select VAC or A
- ③ Insert Black (-) Test Lead to COM input terminal and insert Red (+) Test Lead into Volts or Current(mA, 10A) input terminal
- ④ Start measurement

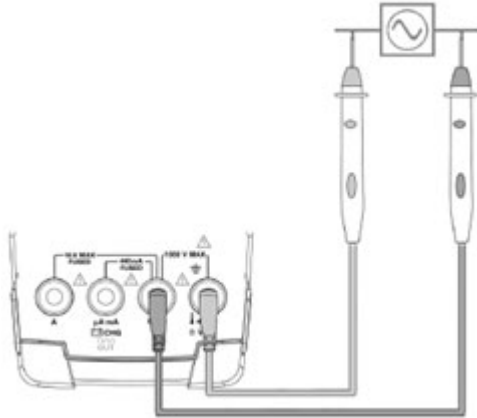

### [Frequency measurement]

#### □ Measurement Range

- Frequency: 0.5Hz ~ 3MHz
- Duty : 5% ~ 95%

□ Measurement Value (AC Voltage, AC Current) is displayed on the Main Display and Frequency, Duty is displayed in the sub display.





□ Hz Sensitivity is dependent upon Frequency Range



## □ Resistance ( $\Omega$ ) measurement

Resistance measurements should be made with all power removed from the circuit and all high power capacitors discharged prior to measurements being made.

Ohm	F1	F2	F3	F4
	Min/Max	<input checked="" type="checkbox"/> Relative	Limit	
	Peak			
	OFF			

- Press the , , or  main function key.
- Next press the  Menu key and select “ $\Omega$ , Continuity, Diode, Capacitance”
- Insert Black (-) Test Lead to COM input terminal and insert Red (+) Test Lead into “ $\Omega$ /cap/Buzzer/Diode” input terminals
- Start measurement

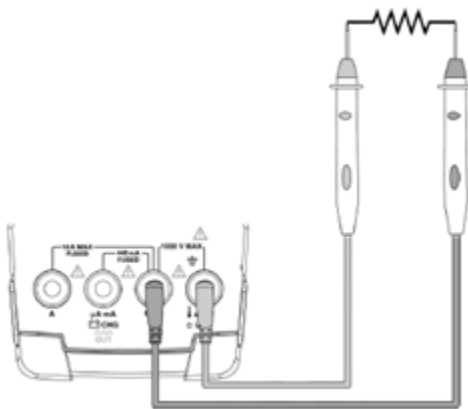

### [Resistance measurement]

- Measurement Range can be selected for Auto Range or Manual Range.
- Measurement Range: 50 $\Omega$ , 500 $\Omega$ , 5000 $\Omega$ , 50k $\Omega$ , 500k $\Omega$ , 5M $\Omega$ , 50M $\Omega$ , 500M $\Omega$  (8 ranges)
- Measured Value is displayed on main display with Bar-Graph display.
- Selectable Sub menu : **Min/Max, Relative, Limit**

### [NOTE]

- Before measuring devices less than 50 ohms , Remove any residual resistance on Test Leads – by momentarily shorting the Test Leads, use F2 “Relative”

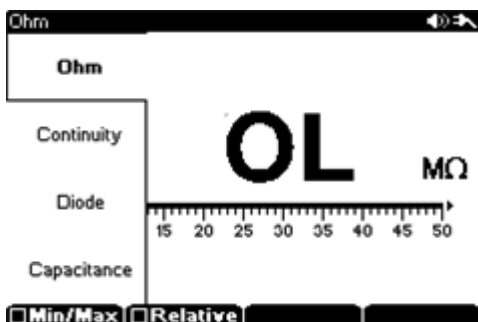

## Continuity Test (🔊)

Continuity checks for open/short circuits. The meter will display the Resistance value and an Open / Short picture on the display. An audible Buzzer will sound for values less than 50Ω.

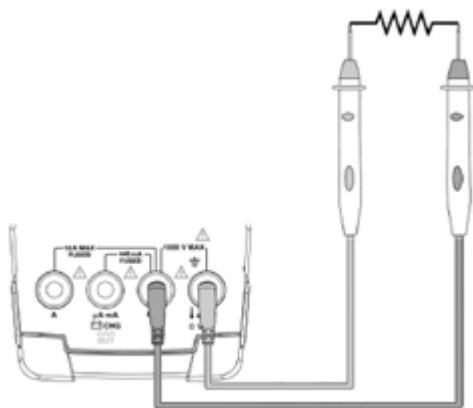

### [Continuity Test]

- Measurement range set automatically
- Range: 500Ω (1 range)
- Buzzer: sounds less than 50Ω
- Measured value is displayed in main display and on the Bar-Graph display.

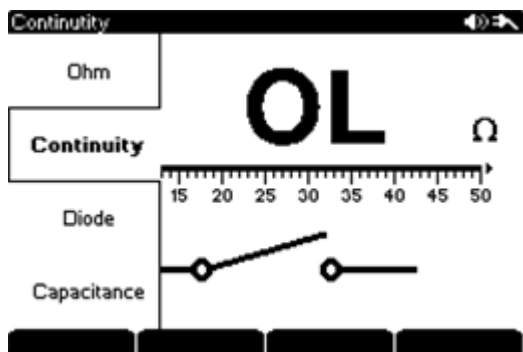

## Diode (→|←) measurement

Checks Diodes, Transistors, Silicon Control Rectifier (SCR) and Semiconductor devices.

Diode	F1	F2	F3	F4
			Limit	

- Generally, the negative (-) terminal of the Diode is marked.
- Can display a Maximum 3.0V forward bias voltage.
- General Forward Bias Voltage is 0.3V~0.8V
- If "OL" is displayed in reverse bias mode, diode is good.
- If both Forward and Reverse bias are 0V, diode is SHORT
- If both Forward and Reverse bias are "OL ", diode is OPEN

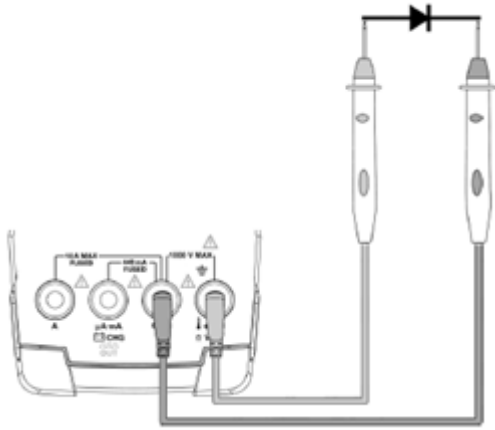

[Diode measurement]

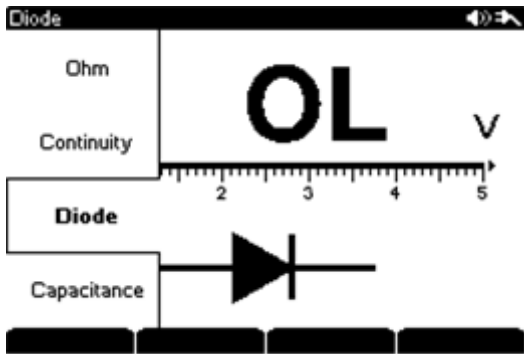

□ Capacitance Measurement (-|+)

Ensure power is removed from the circuit before checking capacitance. Discharge all high powered capacitors prior to measurement.

Voltage	F1	F2	F3	F4
	Min/Max	Relative	Limit	
	Peak			
	OFF			

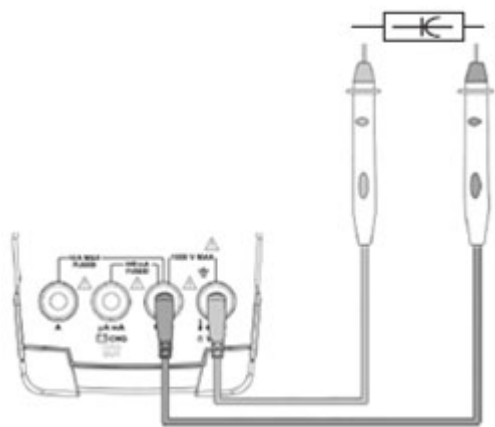

[Capacitance measurement]

- Measurement Range can be selected for Auto Range or Manual Range.
- Range: 5nF, 50nF, 500nF, 5μF, 50μF, 500μF (6 ranges)
- Count : 5,000 counts
- Measured value is displayed on the main display along with Bar-Graph display.
- Sub Menu selectable : **Min/Max, Relative, Limit**

[NOTE]

- When measuring high capacity capacitance values, discharge the capacitors and select an appropriate measurement range to save measurement time and to get accurate measurement values.
- When measuring low capacity capacitance values, short the test leads and press “Relative” to remove any residue Capacitance on Test Lead/Probes.

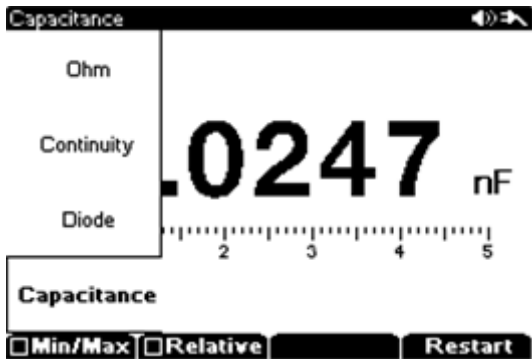



### AUX Measurements

Meter can measure Temperature, Currents, Relative Humidity and Pressure by connecting external Probes. Bar-Graph can be Bi-Directional or Single Directional depending on Mode.

- Temperature, & DC Amps are Bi- Directional with negative scale left of “0” point.
- Humidity, Pressure, & AC Amps are single directions with scale to right of “0” point.

AUX	F1	F2	F3	F4
	Min/Max	<input checked="" type="checkbox"/> Relative	Temp	
	Peak		Ampere	
	OFF		Humidity	
			Pressure	

- Press the  main function key.
- Next press the  Menu key and select “**AUX**” among VAC, VDC, VAC+DC, AUX
- Press the Sub-Menu “F3” key to select “Temp, Ampere, Humidity, or Pressure
- Insert (-) Plug of Adapter to COM input terminal and insert (+) plug of Adapter into AUX input terminal.
- Start measurement

- Measurement Display rate: **1mV = 1°C, 1%, 1A, 1Pa.**
- Temperature: **Main display °C and Sub display °F displayed simultaneously.**
- The Accessories Output Value Unit should be checked before using the Device.

[For example]

If  $10\text{mV} = 1^\circ\text{C}$  or  $0.1\text{mV} = 1^\circ\text{C}$ , should apply  $\div 10$ ,  $\times 10$  on the displayed value.

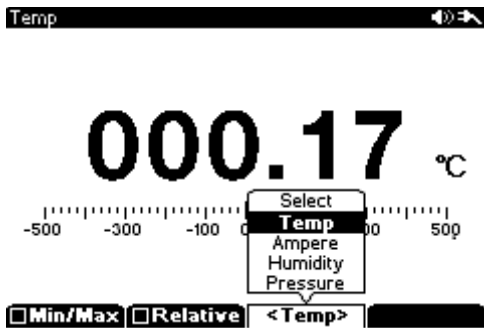

### □ Power Efficiency Measurement

Convenient DC to DC converter efficiency can be measured and displayed without any manual calculations. Power Efficiency is most important on DC to DC Converter,

Set measurement function and measure. Simply Input the Primary and Secondary measurements in order. You can use the Directional Keys to shift measurement locations.

- DC Voltage:  $50\text{mV} \sim 1000\text{V}$
- DC Current:  $500\mu\text{A} \sim 10\text{A}$

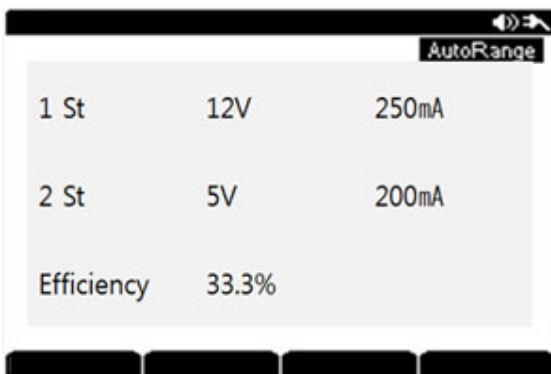



## □ Ripple Noise(Dual Mode) Measurement

- Useful for measuring AC Noise on DC Power Circuits.
- Will measure Ripple Noise values below 100 kHz.
- Easy to accomplish measurement without the need of an O-scope.

-DC Voltage, AC Voltage measurements both display on the LCD screen.

This unique function is different from AC+DC Measurement function of the Meter.

- Measure DC Voltage and AC voltage in Order in display.

- DC/V Range: 5V~1000V.

- AC/V Range: 50mV~500mV.

- Ripple Noise Frequency is displayed simultaneously.

- Measured Values Auto Hold on the display. Reset to take next measurement values.

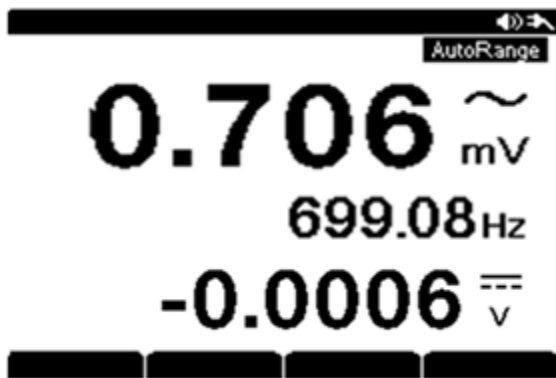

## Signal Out (方波)

The meter can output a Square wave which can generate PWM (Pulse Width Modulation) generation or supply a Synchronous clock signal (Transmission Speed generator). This function allows for checking and calibration of Water Flow Meter display, Counter, Tachometer, Oscilloscope, Frequency converter, Frequency Transmitter and other Frequency Input Devices.

Signal Output	F1	F2	F3	F4
	▲▼Freq	◀▶Duty		

[Signal Output]

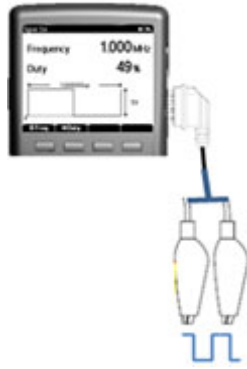

Select main function “ ” key .

- Press sub menu “F1” frequency to change Frequency Output
- Press “F2” Duty to change Duty of Frequency Output

- Output Frequency: 5Hz ~ 1000kHz
- Duty : 5% ~ 95%
- Output level : 3.3V

1) To Adjust the Frequency Output

- Press the sub menu “F1” key to set Output Frequency
- Use the UP/DOWN directions keys to adjust the value.
- Frequency is displayed on main display.
- Minimum Changeable Resolution is 1Hz.
- Default Frequency Output set up at 1kHz.

2) Output Duty Cycle Change

- Press the Sub menu “F2” key to set Duty Cycle (%).
- Use the UP/DOWN directions keys to adjust the value.
- Duty Adjustable Range 5% ~ 95% by 1% steps.
- Initial Duty Set up at 50%.

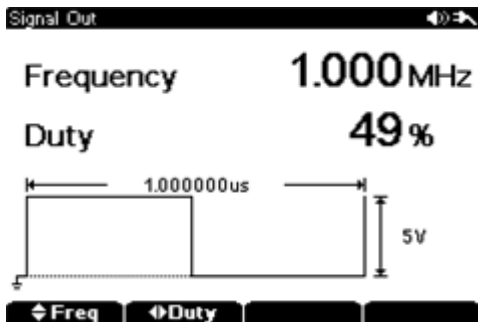

# Logic Analyzer

Logic Analyzer is used to observe Digital Signal Values. Can check whether the digital signal output is normal, Meter has 8 Input Port (Logic 1 ~ 8) as below diagram. 8 digital line data can be seen simultaneously which is useful to check relation to other signals and timing. Logic Analyzer mode is Pattern based or Duration based.



[Protocol Analyzer connection]

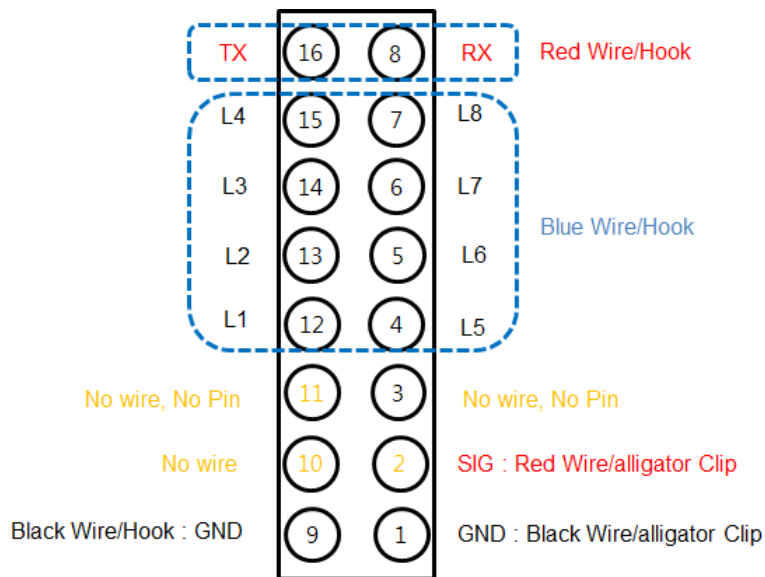

[Logic Cable]

Pin No	Function	Pin No	Function
1	Ground(Black/Clip)	9	Ground(Black/Hook)
2	Signal out(Red/Clip)	10	N/A
3	N/A(pin cutting)	11	N/A(pin cutting)
4	Logic5(Blue/Hook)	12	Logic1(Blue/Hook)
5	Logic6(Blue/Hook)	13	Logic2(Blue/Hook)
6	Logic7(Blue/Hook)	14	Logic3(Blue/Hook)
7	Logic8(Blue/Hook)	15	Logic4(Blue/Hook)
8	Pattern Generator RX(Red/Hook)	16	Pattern Generator TX(Red/Hook)

[Logic Analyzer measurement procedure]

[Major Specifications]

**WARNING: Maximum Input Voltage that can measured is 10V**

- Input Voltage : 0 ~ 10 V
- Channel: 8 ch
- Time/div Range: 50ns/div ~ 50ms/div, 1-2-5 Increments
- Sample Rate: Max.50 Mbps per channel
- Memory Depth: 1kbits/Channel
- Cursor: Supports horizontal cursors

[Channel Input Connection]

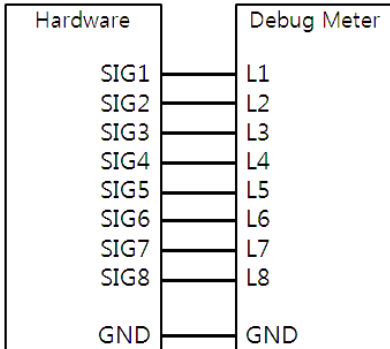

[Logic Analyzer Signal Line Connection]

The Logic Analyzer and the Target Hardware is generally connected as in the above diagram, however, some connections can be changed as required for the test being conducted.

Left area of the Display shows the CH (Channel) numbers.

[Measurement procedure]

- Press main function "LOGIC"  key.
- Insert the plug of the Logic Cable to the Input Socket Terminal on the right side of the Meter. Connect the Hooks of the Logic Test Cable to the Signal Lines to be checked.
- Press the "MENU" key and press Sub menu "F1" key to select the Time/div setting and set the Sampling Rate with the Left-Right directional keys.
- Press the "F2" Trigger key and set the trigger conditions.
- Press the "F4" Condition key to select detailed conditions such as Mode, Channel, Logic,
- Press the "HOLD/RUN" key on the Meter to start Data Acquisition. Press the HOLD/RUN key again to stop the Data Acquisition mode. In Single Trigger mode, Each Data Acquisition is stored with each time the HOLD/RUN key pressed.
- SAVING the Data Acquisition is available when Display is in the Hold or Stop mode. Press the "Save/Recall" key to save the Data.

[Menu Description]

First select the Logic Mode using Main Menu key(Menu/User). Logic Mode consists of Pattern and Duration and then set the Sub Menu F1(Horizontal) F2(Trigger) F3(Cursor) F4(Condition). Horizontal, Trigger, and Cursor settings the same as in the Oscilloscope mode. Refer to the explanation of Oscilloscope (SCOPE) functions for more details.

Common	F1	F2	F3	F4
	Horizontal	Trigger..	Cursor	Condition
	Time Division			
	Time Position			

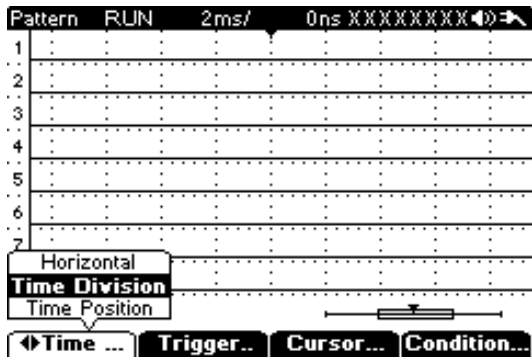

[Trigger Menu settings]

Trigger	F1	F2	F3	F4
	Mode	Source	Level	(Blank)
	Auto	Ch1	Auto	
	Normal	Ch2	▲ ▼ Manual	
	Single	Ch3		
		Ch4		
		Ch5		
		Ch6		
		Ch7		
		Ch8		

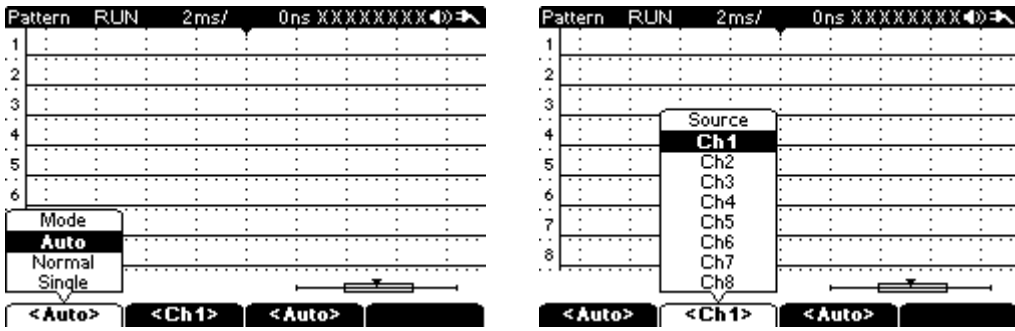

**[Cursor Menu setting]**

**Condition setting**

The logic function consists of Pattern and Duration. Conditional settings of Pattern and Duration is explained below.

**[Pattern Mode]**

Use F1(Channel) and F2(Logic) Function key to select logic condition of each Channel among 1, 0, X(Don't care), Rising Edge, Falling Edge . Triggering is activated when satisfy logic condition set at each 8 channel. The Channels selected as X among 5 kind logic condition are not included in the Trigger condition. Rising/Falling Edge can be selected 1 Channel only among 8 Channel. Other Channels except the channel selected for Rising/Falling can select among 1,0,X which enables conditions for Edge trigger. Edge trigger is activated from the respective edge Polarity (F4) does not have Edge condition and works when all Channels are set Level condition(1, 0, X).

Entered means the Trigger starts when Level Condition exists at the beginning of the time interval.

Exited means the Trigger starts when Exiting from the time interval.

Condition	F1	F2	F3	F4
	Channel	Logic	(Blank)	Polarity
Ch 1		1		Entered
Ch 2		0		Exited
Ch 3		X		
Ch 4		Rising		
Ch 5		Falling		
Ch 6				
Ch 7				
Ch 8				

When each Channel has it's selected logic condition, the upper right area of the screen will display the trigger condition set for each channel as shown on the below screen.

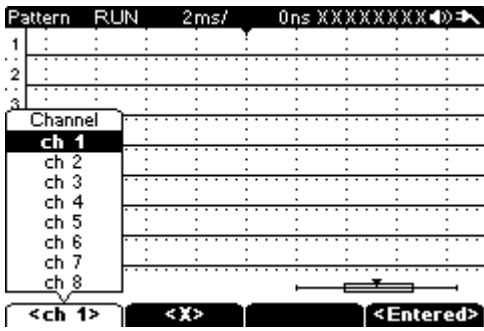

**[Duration Mode]**

Duration Mode is similar to Pattern Mode in the selection of Logic level conditions (1, 0, X(Don't care) of each channel. Pulse Width Triggering is activated after the measured time of Positive Pulse Width Time Interval signal satisfies the set logic conditions.

In this mode, the Logic level 'X' can't be used as a Trigger Condition.

Duration Mode is different from Pattern Mode as outlined below.

1) Triggering occurs based on Time of Positive Pulse Width when it satisfies the trigger level condition. Duration mode does not require a Rising/Falling Edge condition. In Duration mode, Trigger always occurs at the Falling Edge (=Exited) of the Pulse when satisfying the Pulse Width condition, therefore Entered/Exited Polarity settings are not required.

2) Decision function of Pulse Width is added. Level Condition added subsidiary conditions -Logic Gate(AND/OR/NAND/NOR) condition, Pulse Width Qualifier(Less than, Greater than, In of Range, Out of Range and Pulse Width setting

Condition	F1	F2	F3	F4
	Channel	Logic	(Blank)	More...
Ch 1		1		
Ch 2		0		
Ch 3		X		
Ch 4				
Ch 5				
Ch 6				
Ch 7				
Ch 8				

Duration (More)	F1	F2	F3	F4
	Logic	Qualifier	Greater than	Less than
	AND	Less	▼▲ >50ns	<60ns
	OR	Greater		
	NAND	In of Range		
	NOR	Out of Range		

[Logic Function Settings]

Logic Gate can be set to 1 subsidiary condition among AND/OR/NAND/NOR in addition to its level condition. AND is when all selected channels are '1'. OR is when '1' selected Channel is more than 1 channel. NAND is when '0' selected channel is more than 1 channel. NOR is when selected all channels selected '0'

Qualifier and Pulse width time settings are the same as the explanation in Oscilloscope (SCOPE) Pulse Width mode.

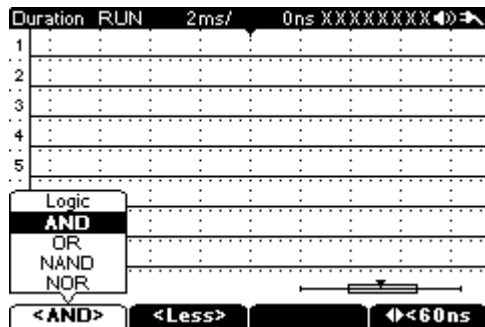



# Protocol Analyzer

The Protocol Analyzer is used to measure Protocol Signals (Serial Bus Data Analyzer). This feature analyzes the performance of RX-TX serial data transmission between DTE (Data Terminal Equipment) and DCE (Data Circuit Terminating Equipment) according to pre-assigned Protocols. It displays TX data (from DTE to DCE) and RX (DEC to DTE) capture status according to Trigger conditions and allows the user to determine if the transmission signals are performed in order.



[Protocol Analyzer connection]

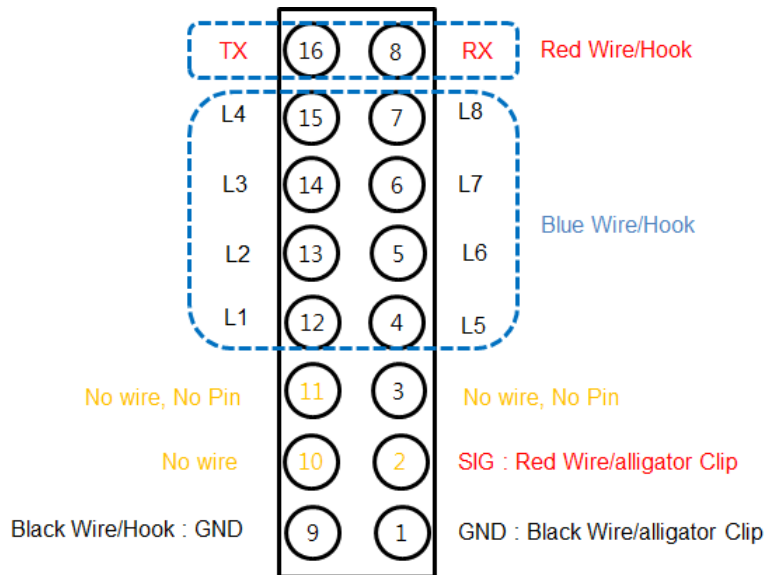

[Logic Cable]

Pin No	Function	Pin No	Function
1	Ground(Black/Clip)	9	Ground(Black/Hook)
2	Signal out(Red/Clip)	10	N/A
3	N/A(pin cutting)	11	N/A(pin cutting)
4	Logic5(Blue/Hook)	12	Logic1(Blue/Hook)
5	Logic6(Blue/Hook)	13	Logic2(Blue/Hook)
6	Logic7(Blue/Hook)	14	Logic3(Blue/Hook)
7	Logic8(Blue/Hook)	15	Logic4(Blue/Hook)
8	Pattern Generator RX(Red/Hook)	16	Pattern Generator TX(Red/Hook)

## [Protocol Analyzer Measuring Procedure]

### [Major Specifications]

Major Specifications are the same as for the Logic Analyzer.

### [Channel Input Connection]



While the Logic Analyzer uses 8 channels freely, the Protocol Analyzer uses fixed channel assignments according to the Protocol Type and Signal Type in the following chart.

Protocol	Signal Type	CH1	CH2	CH3	CH4	CH5	CH6	Trigger Source Selection	Description
CAN	High Speed	C_H	C_L	TX	RX			Yes	Differential
	Fault Tolerant	C_H	C_L	TX	RX			Yes	Differential
	Single Wire	C_Bus		TXRX				Yes	Single-Ended
LIN		LIN	TX	RX				Yes	
UART	UART	U_TX	U_RX					Yes	Single-Ended
	RS232			TXD	RXD			Yes	Inverted
	RS422			TXD+	RXD+	TXD-	RXD-	Yes	Differential
	RS485			TRXD+	TRXD-			Yes	Differential
I2C		SDA	SCL					No	
SMBus		SMBDAT	SMBCLK					No	
USB		D+	D-					No	
I2S		SD	SCK	WS				No	
SPI	SPI-4W	MISO	MOSI	SCK	/SS			No	
	Microwire	DI	DO	CLK	CS			No	
	Other SPI	SDIO	SDO	SCLK	/CS			No	
DMX512		U_TX	U_RX	+S	-S			Yes	
1-Wire		I/O						No	

When each Protocol is selected, the lower area of the display shows the signal name connected to each channel number. For example, (I2S on above Chart), the displays shows 1: SDA, 2: SCL. The Trigger Source Selection field in the Right Column of above table shows Yes (Enable) or No (Disable), Protocol type showing YES can change Trigger Source of channel being used, this is because the Trigger Source of the protocol is fixed to the specific Channel or all channels are used together.

### [Measurement procedure]



- Press the “PROTOCOL”  Main Function key.
- Press the MENU key and select the Protocol Type ; CAN, LIN, I2C, UART, USB, I2S, SMBus, SPI, DMX512, 1-Wire
- Insert the Plug of the Logic Cable to the Input Socket Terminal on the right side of the Meter. Connect the hooks of the Logic Cables to the Signal Lines to be checked.
- Select the Sub Menu “F1” Time/div  and set the Sampling Rate with the Left-Right direction keys.
- Press “F2” Trigger Mode key to set Conditions related to Triggering.
- Decide which Channels will capture Triggers.
- [NOTE] Some Protocols do not require Trigger Source selection. Refer to above mentioned diagram for signal requirements [Channel Input Connection.]
- Press the “F4” Condition key to select each Protocol ‘detailed conditions like as Trigger Mode, Baud Rate, signal Type.
- Press the “HOLD/RUN” key on the Meter to start Data Acquisition. Press the “HOLD/RUN” key again to stop Data Acquisition. In Single Trigger mode, Each Data Acquisition record is saved each time the “HOLD/RUN” key is pressed.
- SAVING the Data is available when the Display is in the Hold or Stop mode. Press the “Save/Recall” key to save the Data to the internal memory.

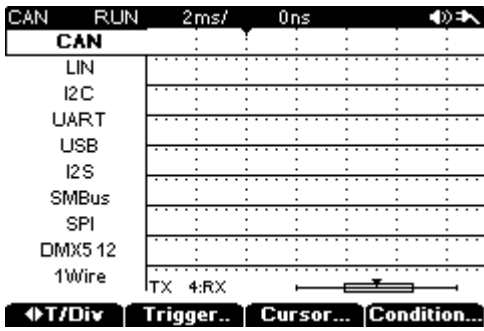

[Menu Description]

First select the Protocol Mode using Main Menu key(Menu/User). And set the Sub Menu F1(Horizontal) F2(Trigger) F3(Cursor) F4(Condition).

Horizontal, Trigger, Cursor setting procedures are same as for the Oscilloscope. Refer to the explanation for the Oscilloscope (SCOPE) function for more detail.

Common	F1	F2	F3	F4
	Horizontal	Trigger	Cursor	Condition
	Time/div Tr Position H Position		OFF X1 X2 X1/X2 Tracer ON	

[Trigger Condition]

Each Protocol type can select following Condition setting.

Type	Condition
CAN	Trigger on Start Frame/End Frame, Baud Rate: 10k ~ 1Mbps, Supports only over Protocol CAN2.0A/B
LIN	Trigger on Sync Break, Baud Rate : 2400 ~ 625kbps
I2C	Trigger on Start/Stop/Missing Ack/Restart, Supports 10bit Write Enable/Disable
UART	Trigger on Start bit/Stop bit/Parity error, Baud Rate: 2400 ~ 921.6kbps
USB	Trigger on SOP/EOP/RC/Suspend/Exit Suspend, Supports only Low/Full Speed
I2S	Trigger on Start bit, Supports WS Selection: Left/Right/Either
SMBus	Trigger on Start/Stop/Missing Ack/Restart, Supports 10bit Write Enable/Disable
SPI	Trigger on Start bit, Supports 4-Wire SPI, Microwire and other 3-Wire SPI protocols
DMX512	Trigger on Break Detect/Start bit
1-Wire	Trigger on Break Detect/Presence Detect/Start bit, Baud Rate: 15.4k / 125kbps

**[Operation by Protocol Type]**

**[CAN]**

Analyze type CAN (Controller Area Network) communication Protocol. Signal Line connections between Meter and target Hardware are as shown in the diagram below.

Left line indicates the Hardware to measure and Right Line indicates the Protocol Input port of the Meter. CAN\_H, CAN\_L are In-Out Signals to the outside of the Hardware through CAN Transceiver, TX, RX are In-Out signals inside of the Hardware. Connection between Signal and Input Channel to be fixed. Can select Trigger Source. To generate Trigger Pulse, Trigger Level can be adjusted to AUTO or MANUAL method.

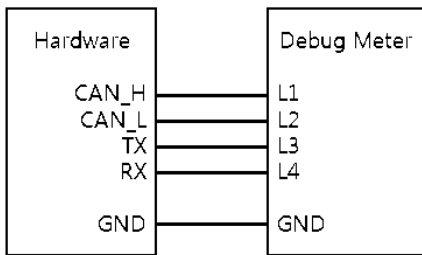

[High Speed CAN / Fault Tolerant CAN]

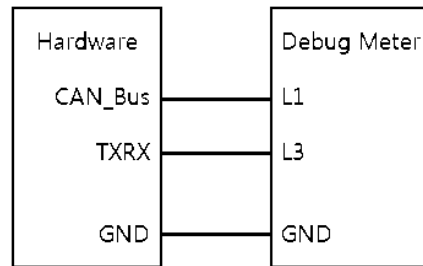

[Single Wire CAN]

**[CAN signal line connection]**

After Signal Lines are connected, select Sub Menu Horizontal (F1), Trigger (F2) to set basic condition for CAN Protocol analyzer. Then, press F4 condition key and set all conditions in following the Sub Menus F1 ~ F4 in order. After all settings are completed, Press the "HOLD/RUN" key on the meter to start the analyzer.

CAN	F1	F2	F3	F4
	Trigger	Baud Rate	Signal	Standard
	Start of Frame	10 k	High Speed	CAN2.0A
	End of Frame	...	Fault Tolerant	CAN2.0B
		1 M	Single Wire	

For Signal Type (F3), High Speed. Fault tolerant is Differential type in 2 lines and Single wire is single-ended type. Select the Baud rate in the F2 menu.

Trigger Condition (F1) supports SOF (Start of Frame) and EOF (End of Frame). Location of Trigger generation timing at each Trigger Condition is shown as below.

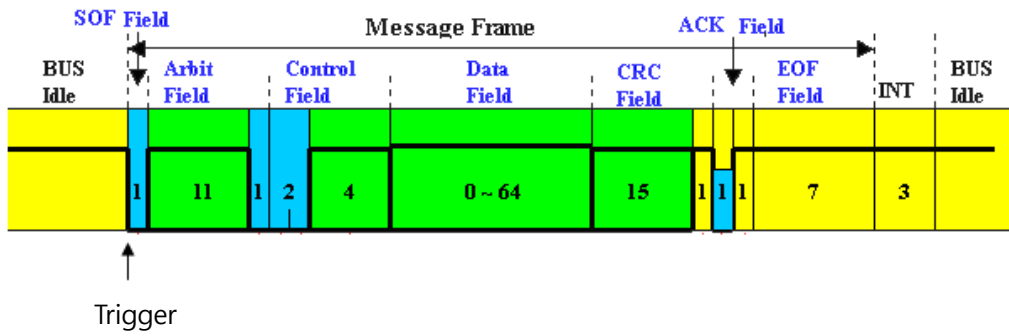

[Start of Frame]

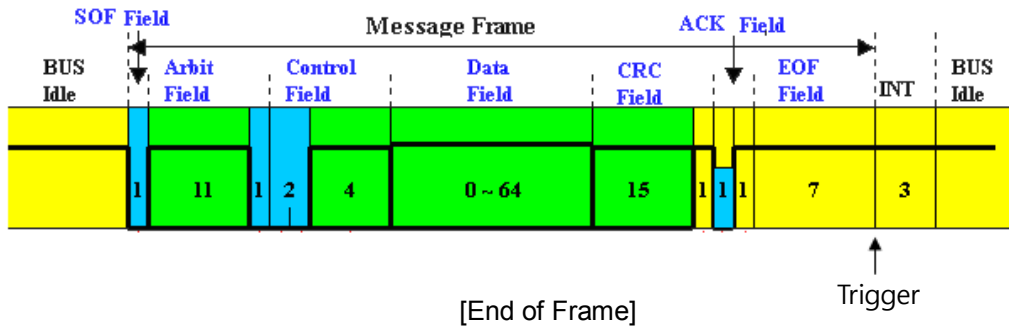

[End of Frame]

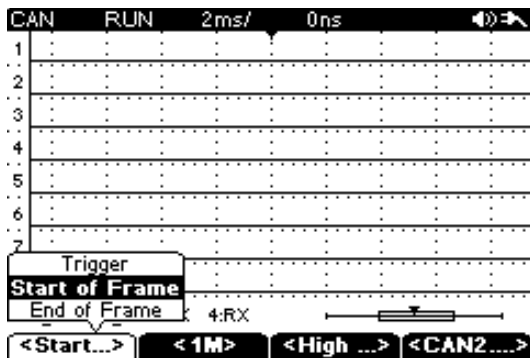

[LIN]

- Analyze type LIN communication Protocol. Signal Line connections between Meter and target Hardware are as shown in the diagram below.
- Left line indicates Hardware to be measured and Right Line indicates Protocol Input port of the Meter. LIN is In-Out Signal to outside of the Hardware through LIN Transceiver. TX, RX are the In-Out signals inside of the Hardware. Connection between Signal and Input Channel to be fixed. Select the Trigger Source. For Trigger Pulse events, Trigger Level can be adjusted to AUTO or MANUAL mode.

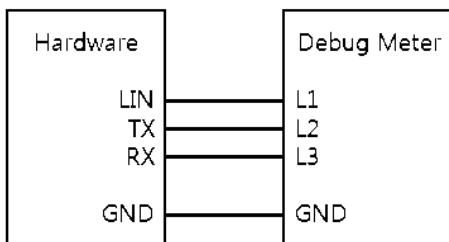

[LIN signal line connection]

After Signal Lines are connected, select Sub Menu Horizontal (F1), Trigger (F2) to set the basic conditions for LIN Protocol analyzer. Then, press F4 condition key and set all conditions in the following Sub Menus F1 ~ F4 in order. After all settings are complete, press the "HOLD/RUN" key on the meter to begin analyzing.

LIN	F1	F2	F3	F4
	Trigger	Baud Rate	Sync Break	(Blank)
	Sync Break	2400	>= 13	
		...	>= 12	
		625 k	>= 11	

Trigger Condition (F1) is fixed at the ending point of Sync Break Time to occur Trigger. Location of Trigger event timing is shown in the below diagram. Condition of Sync Break Time can be adjusted from 11 ~ 13 bit through the "F3" menu key. The "F2" menu key can be used to select Baud rate.

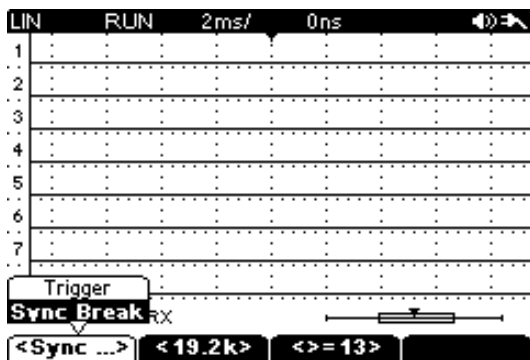
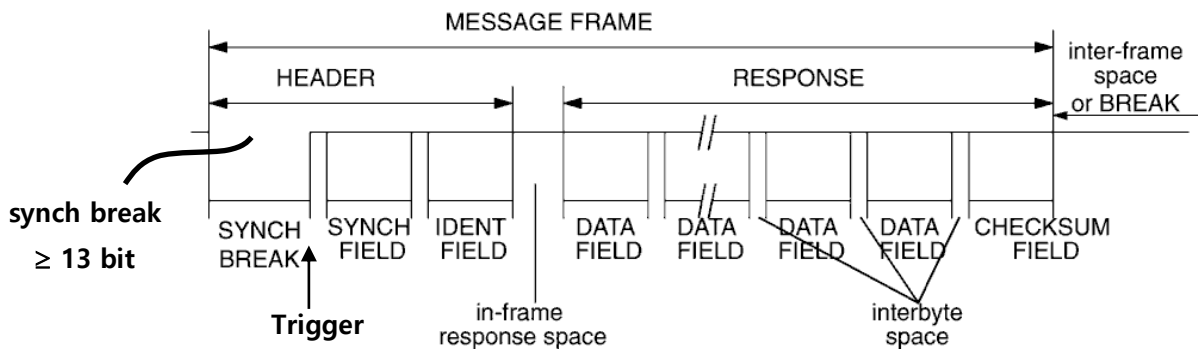

**[I2C]**

Analyze type I2C communication protocol. Signal Line connections between Meter and target Hardware are as below diagram.

Left line indicates Hardware to measure and Right Line indicates Protocol Input port of the Meter. Connection between the Signal and Input Channel is to be fixed. Trigger Source selection is not required. For Trigger Pulse event, Trigger Level can be adjusted to AUTO or MANUAL mode.

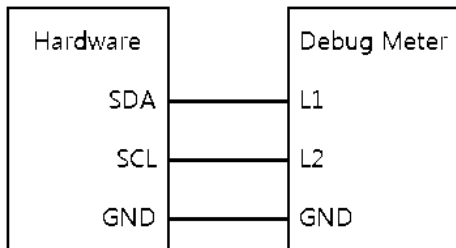

[I2C signal line connection]

After Signal Lines are connected, select the Sub Menu Horizontal “F1”, Trigger “F2” to set basic condition for I2C Protocol analyzer. Then, press the “F4” condition key and set all conditions in following Sub Menu in F1 ~ F4 in order. After all settings are correct, press HOLD/RUN key on the Meter to begin Analysis.

I2C	F1	F2	F3	F4
	Trigger	10bit Write		
	Start	Disable		
	Stop	Enable		
	Missing ack			
	Restart			

Before setting the Trigger Condition, select the Address Write mode in Sub Menu (F2). I2C Address generally uses 7-bit .then select disable. And select Trigger Condition (F1) among Start/Stop/Missing ack (Acknowledge)/Restart. Frame structure, Function of each condition and Trigger event point location as below.

I2C basic Frame (shown below) is consist of Start bit(S) and Stop bit (P), which informs Start and End of Frame, 8-bit Data (Addr+R/W or Data) in between Start Bit and Stop Bit and Acknowledge bit (A)

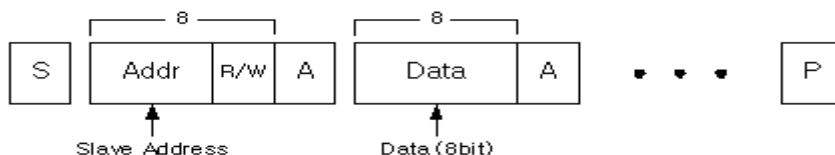

**[S]** Start bit indicates start of I2C Protocol.

**[Addr]** address when call Slave Device. Generally 7bit, When 10-bit Address, makes 10bit utilizing next data as Address. When 10bit write mode Address Byte is 11110xx0.

**[R/W]** informs whether READ Mode (“1”) or WRITE Mode (“0”)

**[A]**Acknowledge signal informs whether Slave Device received Data well.

**[Data]** 8-bit Transmit Data or Receiving data

**[P]** Stop bit indicated finish of I2C.

- Start (Start Condition):

Trigger event when SCL signal is HIGH and SDA changes "HIGH" to "LOW"

- Stop ( Stop Condition ):

Trigger event when SCL signal is HIGH and SDA changes "LOW "to "HIGH"

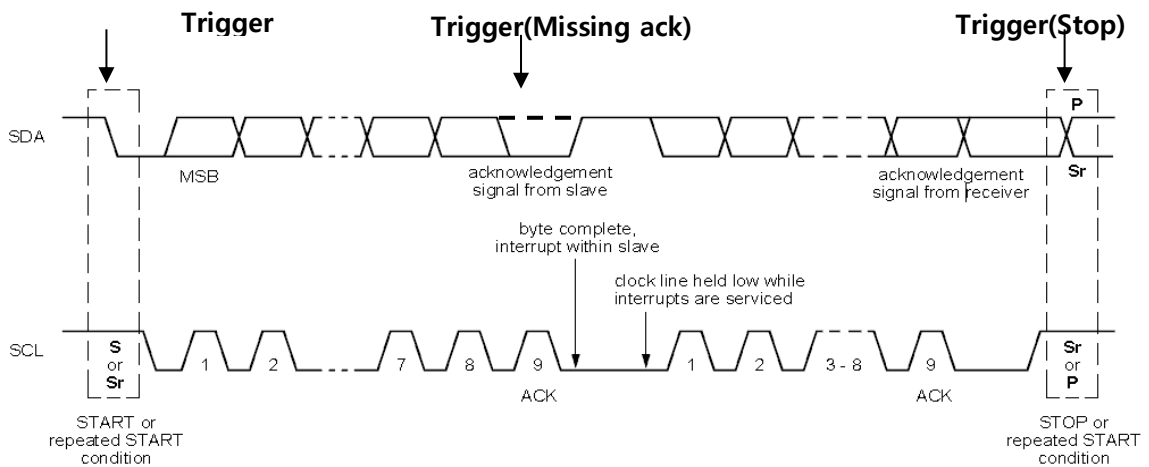

- Missing ack (Missing Acknowledge Condition):

Acknowledge bit informs Master whether Slave Device received data correctly. If the received Data is good, it sends "0", If it did not receive good Data, it sends "1" Missing ack Trigger occurs when data is not received when Acknowledge bit is "1".

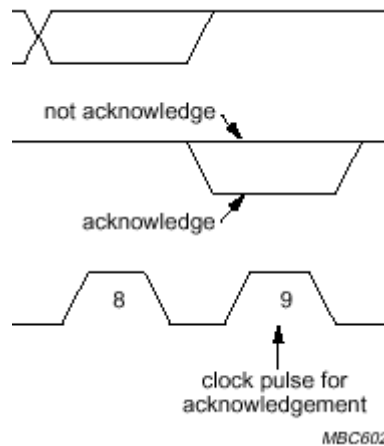

- Restart (Repeated Start Condition): Restart bit (RS or Sr) is used when Master start to read Data from Slave. Consists of 1-bit. Restart occurs if start while not in Stop Condition (P) after start condition(S) and trigger at Falling edge.



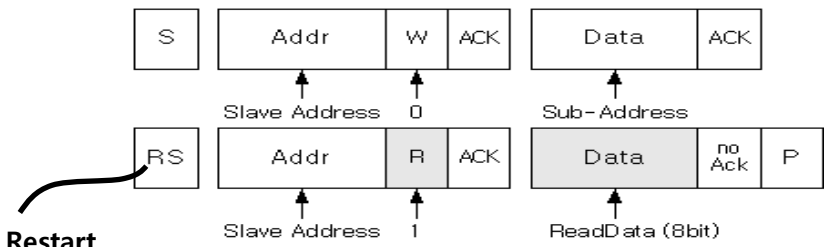

**Restart Condition**

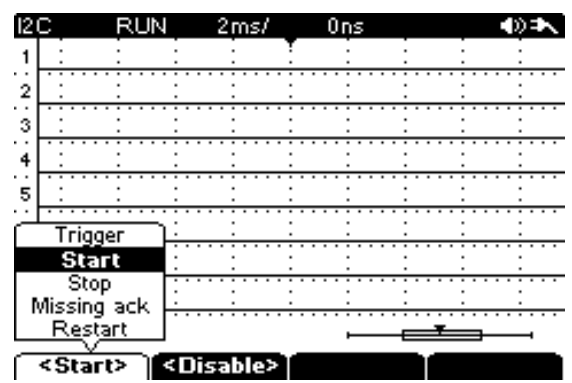
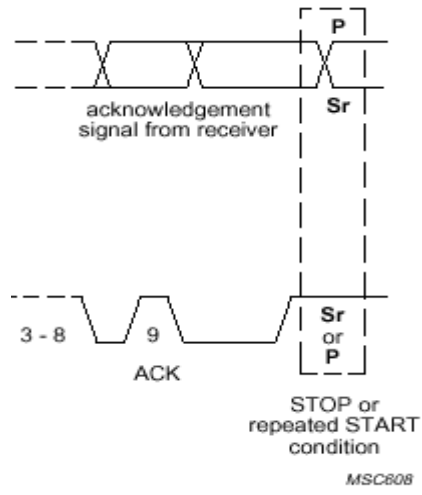

**[UART]**

Analyze the UART communication Protocol. Connection of the Signal lines is accomplished between the Meter and the hardware as shown in the diagrams below. Triggering is available for RS232, RS422, RS485 (utilizing URAT) as well as UART within the safe voltage range. Left lines are for Hardware to be measured and Right Lines are Input Port of Protocol of Meter. UART signal name indicated as U\_TX/U\_RX. (refer to the below UART diagram). RS232/RS422/RS485 connects In-Out signal to outside with Input Channel through Transceiver. Connection between Input Channels and Protocol signals are fixed. Select the Trigger Source among the channels being used, and you can adjust the Trigger Level for Auto or MANUAL modes for Trigger Pulse events. RS232/RS422/RS485 are supported within Input Voltage (0 ~ 10 V) range, Trigger Level need to be adjusted properly when Offset is included in the Input signal. Differential Protocol RS422, RS485 does not support Differential method, +, - each signal treated same as Single ended method which requires attention the Polarity + - .

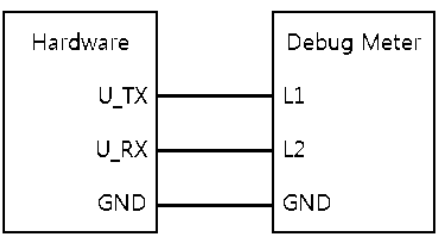

[UART]

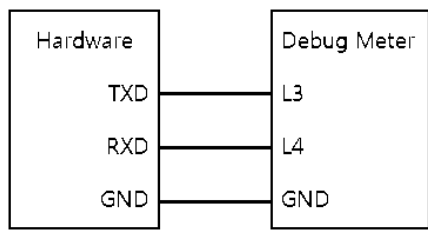

[RS232]

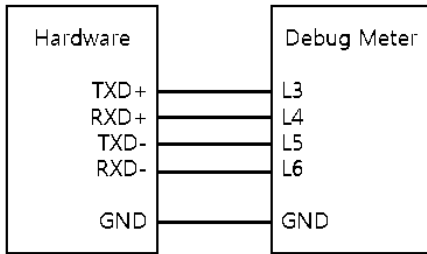

[RS422]

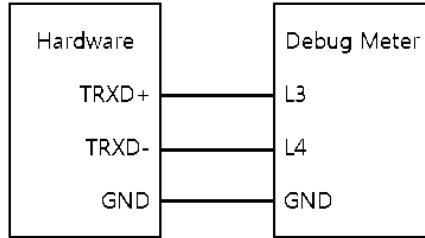

[RS485]

[UART signal Line connection]

After Signal Lines are connected, select Sub Menu Horizontal (F1), Trigger (F2) to set basic condition for UART Protocol analyzer. Then, press the “F4” condition key and set all conditions in the following Sub Menu’s F1 ~ F4 in order. After all settings are complete, press the HOLD/RUN key on the Meter to start the Analysis.

UART	F1	F2	F3	F4
	Trigger	Baud Rate	Signal	More...
	Start bit	2400	UART	
	Stop bit	4800	RS232	
	Parity error	9600	RS422	
		19200	RS485	
		38400		
		57600		
		115200		
		230400		
		460800		
		921600		

UART	F1	F2	F3	F4
(More)	Data Bits	Parity	Stop Bits	(Blank)
	8 bit	none	1 bit	
		even	2 bit	
		odd		
		space		
		mark		

- Trigger Condition (F1) can be used to select Start bit, Stop bit or Parity error.  
Basic timing and Each Trigger Condition is described below

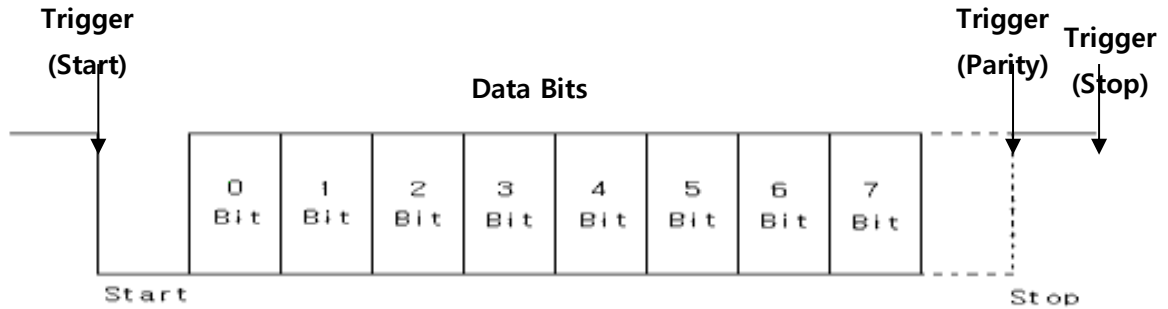

Start bit: Trigger event starts at ('H' -> 'L') of beginning point of Start bit.

Stop bit: Trigger event at the ending point of Stop bit. Length of Stop bit can be set in Sub Menu (F4)> Stop Bits (F3)

Parity error (Parity bit error condition): Trigger event to recognize Parity Error; Real Value does not match with the value set in Parity Condition (Sub Menu (F4) > Parity (2)). Trigger point is the starting point of Stop Bit after Parity bit.

Parity menu (F2) is as below

- None: Parity bit is not used.
- Even: Count number of 1 out of total Data Byte. Make parity bit value '0' or '1' so that the total number of '1' in both of parity bit and all the Data bits to be even and send. For example, if select Even Parity, when the total number of '1' in Data Byte is even, parity should be '0'. Speaking more concretely, if Data is "01100011", number of '1' is even and then the parity bit becomes '0'. But if Data is "11010110", number of '1' is odd, so the parity bit becomes '1' to make the total number of '1' to be even number.
- Odd: opposite from Even. Count number of 1 out of total Data Byte. Make parity bit value "0" or '1' so that number of 1 to be Odd number and Send.
- Space: Parity bit is fixed '0'. Check Parity bit.
- Mark: Parity bit is fixed '1'. Check Parity bit.

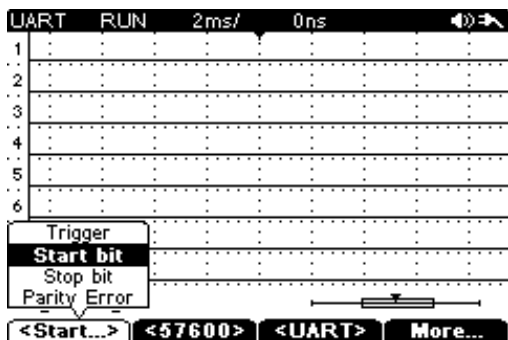

## [USB]

- Analyze type USB communication Protocol. Signal line between Meter and Hardware connected as per below diagram. Left line indicates Hardware to measure and Right Line indicates USB Protocol Input port of the Meter. Connection between Signal and Input Channel to be fixed. Trigger Source selection is not required. For Trigger Pulse event, Trigger Level can be adjusted AUTO or MANUAL mode.

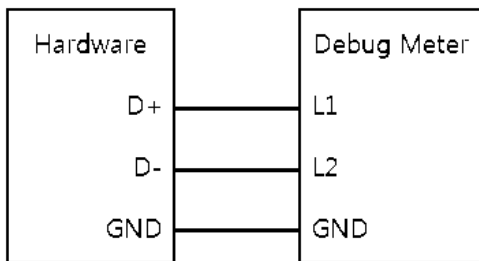

[USB signal Line connection]

- After Signal Lines are connected, select the Sub Menu Horizontal (F1), Trigger (F2) to set basic conditions for USB Protocol analyzer. Then, press “F4” condition key and set all conditions in the following Sub Menu’s for F1 ~ F4 in order. After all settings are complete, press the HOLD/RUN key on the Meter to start Analysis.

USB	F1	F2	F3	F4
	Trigger	Speed		
	SOP EOP RC Suspend Exit Suspend	Low Speed Full Speed		

You must select the Speed for the USB Trigger (F2). USB Trigger supports Low Speed/ Full Speed but does not support High Speed. There is difference in the Signal Level of Packets between Low speed and Full speed as below.

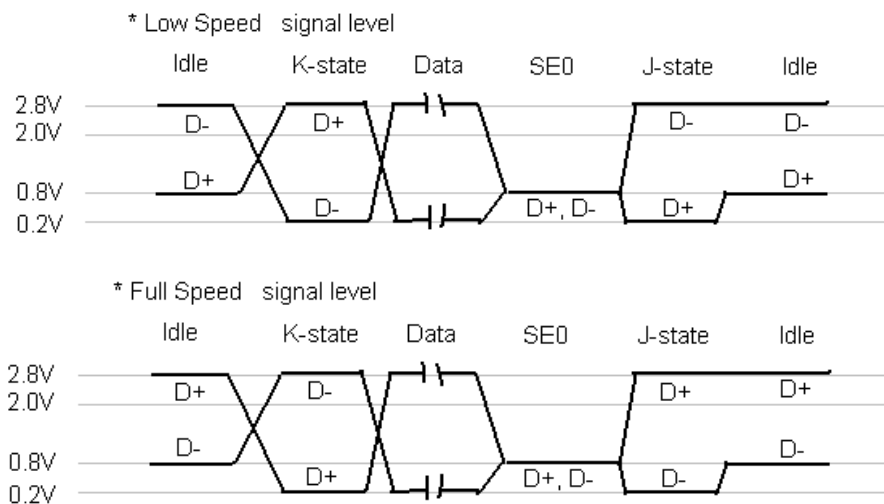

Trigger condition Menu (F1) has 5 options – SOP (Start of Packet), EOP(End of Packet), RC(Reset Complete), Suspend(Enter Suspend) and Exit Suspend.

SOP (Start of Packet): Trigger event at Sync Bit of beginning of USB Packet



EOP (End of Packet) : Trigger event at beginning point of J state.



RC (Reset complete): EOP Trigger when SE0 is over 10ms. This signal is for Reset. Trigger event when change to state when SE0 is over 10ms.

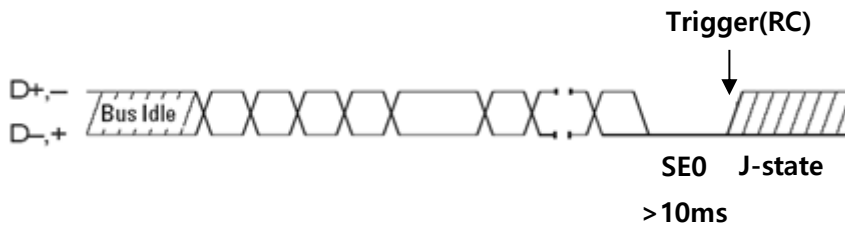

Suspend (Enter Suspend) : Trigger event at the point when Idle state is longer than 3ms after completion of J state

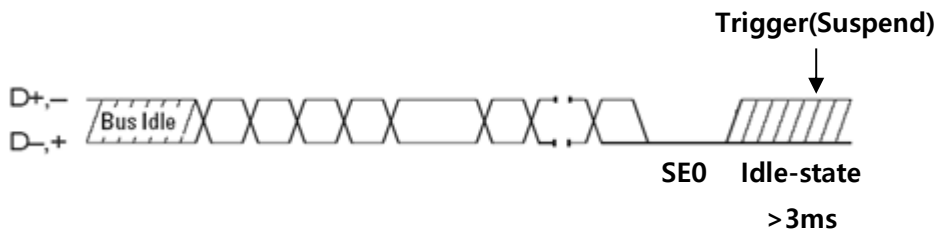

Exit Suspend: Trigger event at SOP point when idle state is longer than 10 ms after completion of J state. This is for checking changing status of Suspend/Resume.

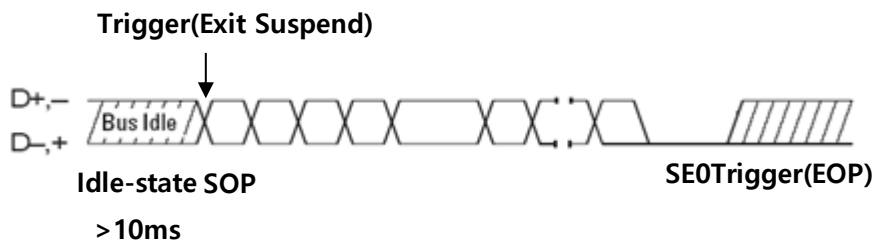

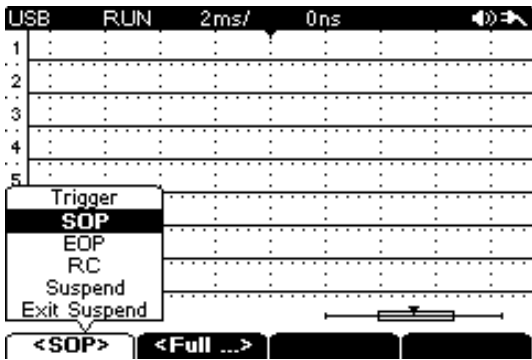

**[I2S]**

Analyze type I2S communication Protocol. Signal line between Meter and Hardware connected as in the diagram below. Left line indicates Hardware to measure and Right Line indicates Protocol Input port of the Meter. Connection between Signal and Input Channel to be fixed, Trigger Source selection is not required. For Trigger Pulse events, Trigger Level can be adjusted AUTO or MANUAL mode.

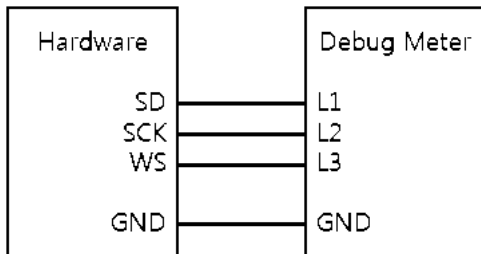

[I2S signal Line Connection]

After Signal Lines are connected, select the Sub Menu Horizontal (F1), Trigger (F2) to set basic conditions for I2S Protocol analyzer. Then, press “F4” condition key and set all conditions in the following Sub Menu’s F1 ~ F4 in order. After all settings are complete, press the “HOLD/RUN” key on the Meter to start Analysis.

	F1	F2	F3	F4
I2S	Trigger	(Blank)	WS Selection	SCK Slope
	Start of Data		Left Right Either	Rising Falling

I2S Protocol is consist of 3 lines: SD (Serial data), SCK (Continuous serial clock) and WS (Word select), to transmit Synchronous Digital Audio Signal.

As shown in the diagram below, it is a Repeating Pattern and that uses WS signal (0: Left, 1: Right) to classify Left/Right channels of Audio Signal. Before I2S trigger, press “F3” Key for WS selection. And press “F4” key to select edge of SCK clock.

Capture Point of Data changeable by SCK edge direction. Trigger Position “F1” is fixed at the Starting point of Data Transmission in selected WS selection.

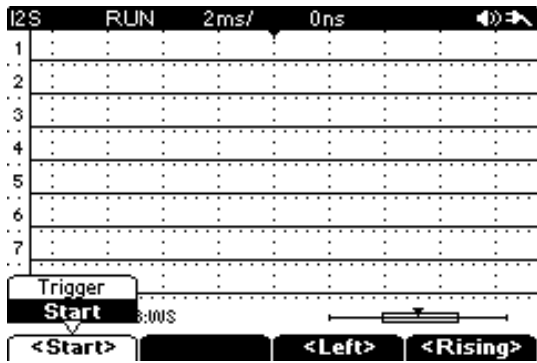
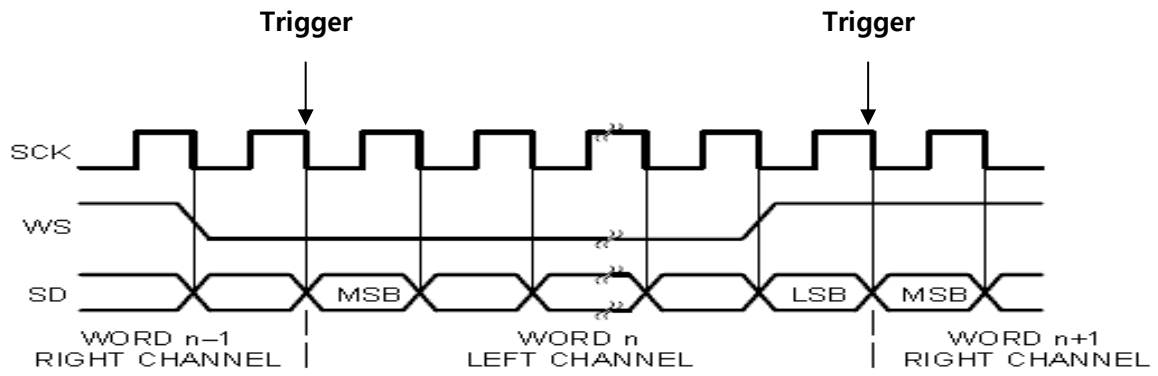

### [SMBus]

Analyze type SMBus communication protocol. Signal Line connections between Meter and target Hardware are shown in the diagram below. Left line indicates Hardware to measure and Right Line indicates Protocol Input port of the Meter. Connection between Signal and Input Channel to be fixed, Trigger Source selection is not required. For Trigger Pulse event, Trigger Level can be adjusted AUTO or MANUAL mode.

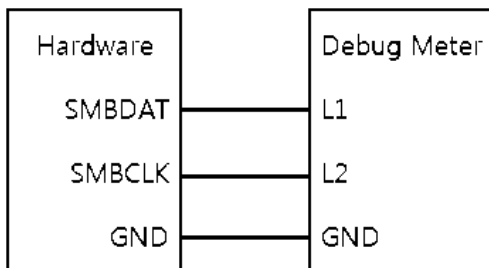

[SMBus signal line connection]

After Signal Lines are connected, select the Sub Menu Horizontal (F1), Trigger (F2) to set basic conditions for SMBus Protocol analyzer. Then, press "F4" condition key and set all the conditions in following Sub Menu's F1 ~ F4 in order. After all settings are complete, press the "HOLD/RUN" key on the Meter to start Analysis.

SMBus	F1	F2	F3	F4
	Trigger	10bit Write		
	Start	Disable		
	Stop	Enable		
	Missing ack			
	Restart			

Press Sub Menu F1 key to select the Trigger Condition among Start/Stop/Missing ack (Acknowledge)/Restart. SMBus Frame Structure, Function by condition Position is similar to I2C. Please refer I2C instructions for details.

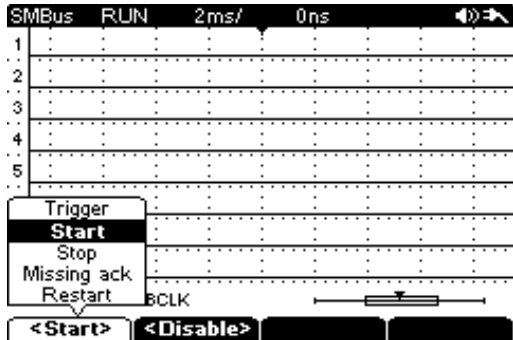

### [SPI]

Analyze type SPI communication Protocol. Signal line between Meter and Hardware connected as shown in the diagram below. Supports 3 types: SPI-4W, micro wire and other SPI,

SPI supports mainly 4-Wire type but will also capture 3-wire type.

Left line indicates Hardware to measure and Right Line indicates Protocol Input port of the Meter. Connection between Signal and Input Channel to be fixed, Trigger Source selection is not required. For Trigger Pulse events, Trigger Level can be adjusted AUTO or MANUAL mode.

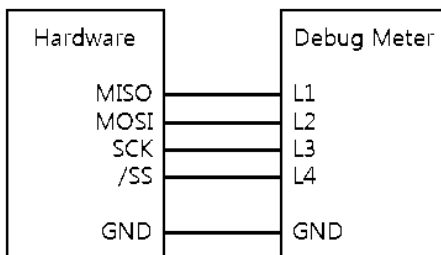

[SPI-4W Signal Line connection]

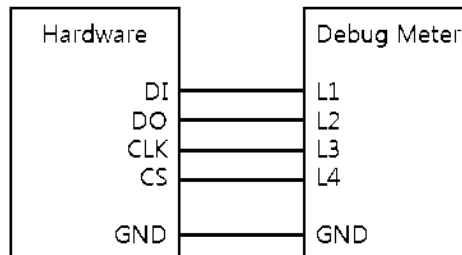

[Microwire Signal Line connection]

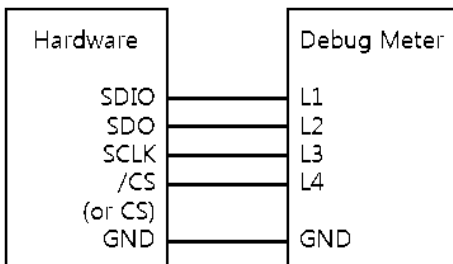

[Other SPI Signal Line connection]



- After Signal Lines are connected, select the Sub Menu Horizontal (F1), Trigger (F2) to set basic conditions for SPI Protocol analyzer. Then, press the “F4” condition key and set all conditions in the following Sub Menu’s “F1 ~ F4” in order. After all settings are complete, press the HOLD/RUN key on the Meter to start Analysis.

SPI	F1	F2	F3	F4
	Trigger	(Blank)	Signal	More...
	Start of Frame End of Frame		SPI-4W Microwire Other SPI	

Press the “F1” Menu Key to select SPI type among SPI-4W, Micro wire, Other SPI.  
**SPI-4W** Mode Setting is as below.

SPI-4W (More)	F1	F2	F3	F4
	Clk Format	Clk Slope	(Blank)	(Blank)
	CPHA=0 CPHA=1	Rising Falling		

SPI-4W consists of 4 lines: Slave Select (/SS), Serial Clock (SCK), Master Out/Slave In (MOSI) and Master In/Slave Out (MISO). Communication is possible when SS Signal is “Low” There are Two Transmission modes and press the “F1” key (Clk Format ) to select “CPHA = 0”.

“CPHA = 0”, as below, Data Is Output once /SS “LOW” . Therefore, Data Latch is available at 1<sup>st</sup> SCK Edge. Trigger event during transition point when /SS change to ”LOW”

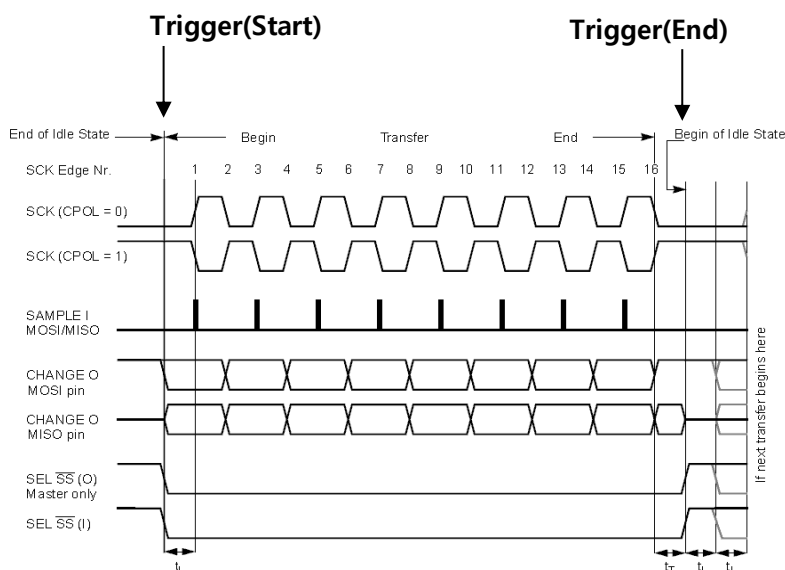

**SPI-4W, SPI Clock Format 0 (CPHA = 0)**

The next mode “CPHA = 1”: Data Output at 1<sup>st</sup> SCK Edge Event after /SS changed to “Low”. Therefore, Data Latch is available at 2<sup>nd</sup> SCK Edge. Trigger event at 1<sup>st</sup> SCK Edge after /SS changed to “Low”

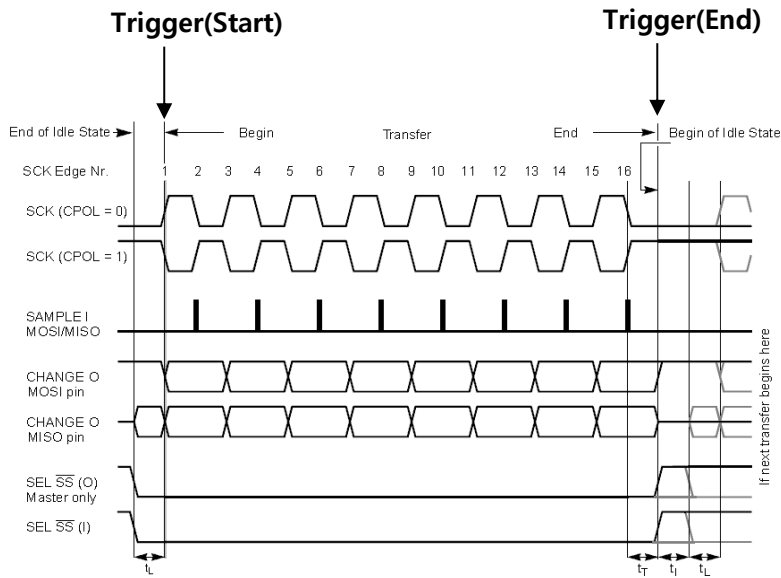

**SPI-4W, SPI Clock Format 1(CPHA = 1)**

In Clk Slope (F2) key, Clock Edge for latching each data can be changed.

**Micro wire** Mode does not have any additional settings.

Micro wire consists of 4 lines: Chip select (CS), Serial clock (CLK), Serial Data in (DI) and Serial Data out (DO) as below Timing Diagram.

Communication is available when CS Signal is “High”.

Trigger Event when CS changes “Low - High”.

Micro wire does not select Clock Phase. Trigger Event during transition when CS changes to “High” like as “CPHA=0” of SPI-4W mode.

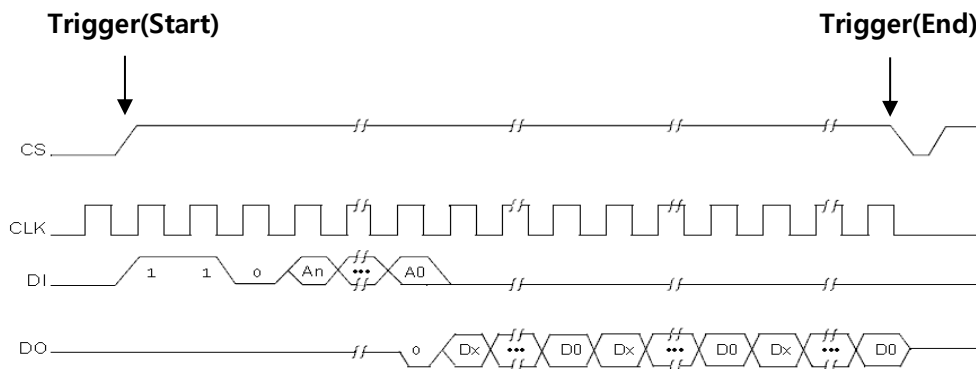

Other SPI Mode Setting is below

Other SPI	F1	F2	F3	F4
(More)	CS Selection	(Blank)	(Blank)	(Blank)
	Active Low			
	Active High			

Other SPI is consist of 4 lines: Chip select (CS), Serial clock (CLK), Serial Data In/Out (SDIO) and Serial Data out (SDO). While Level of Chip Select Signal in SPI-4W and Micro wire is fixed "0" or "1", Other SPI can select Level of Chip Select "0/1".

In F1 Menu, When "Active Low", Trigger event when CS Selection is "High -> Low". On the contrary, When "Active High". Trigger event when CS selection "Low -> High"

The mode can't select Clock Phase, Trigger event during transition when CS change, other working process is similar with SPI-4W or Micro wire. 3-Wire SPI has only 1 line data which does not connect with SDO and use SDIO only. Other working process is similar as 4-wire.

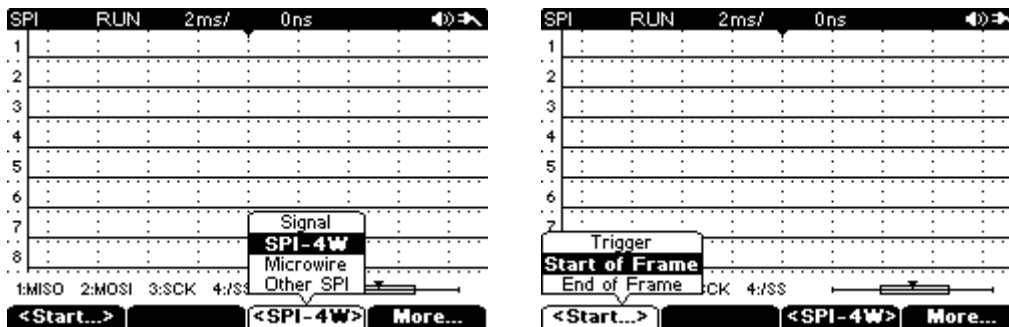

### [DMX512]

Analyze type DMX 512 communication Protocol. Signal lines between Meter and Hardware connected as below diagram. Left line indicates Hardware to measure and Right Line indicates Protocol Input port of the Meter. Similar to RS 485 Communication Protocol and Capture signal before or after go through transceiver. Should use within Input Voltage range (0~10 V).

Connection between Signal and Input Channel to be fixed, Can select Trigger Source among the Channels being used. For Trigger Pulse event, Trigger Level can be adjusted AUTO or MANUAL mode.

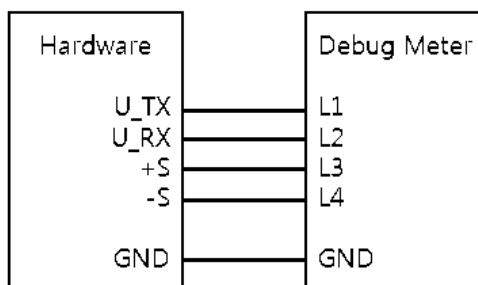

[DMX512 Signal Line Connection]

- After Signal Lines are connected, select the Sub Menu Horizontal (F1), Trigger (F2) to set basic condition for DMX 512 Protocol analyzer. Then, press “F4” condition key and set all conditions in the following Sub Menu’s “F1 ~ F4” in order. After all set, press HOLD/RUN key on the Meter to start Analysis.

DMX512	F1	F2	F3	F4
	Trigger			
	First Start Break Detect			

Packet of DMX 512 Protocol starts at “Break” condition that output “Low” signal over 88µSec like below picture. And stay in “High” during MAB (Mark after Break) time and start Data transmission. Data Transmission start to transmit Start Code of 1Byte length and transmit data from Ch1 to max 512 Ch in order. Frame of Each channel is consist of Start bit (1- bit), Data (8 bit) and Stop bit (2 bit). Between Frame and Frame, need Time Interval called MTBF. Meter can select Trigger mode with F1 Function Key. Support Trigger Event at “First Start bit” time – Start bit of Start Code and “Break Detect” time – Ending point of Break time.

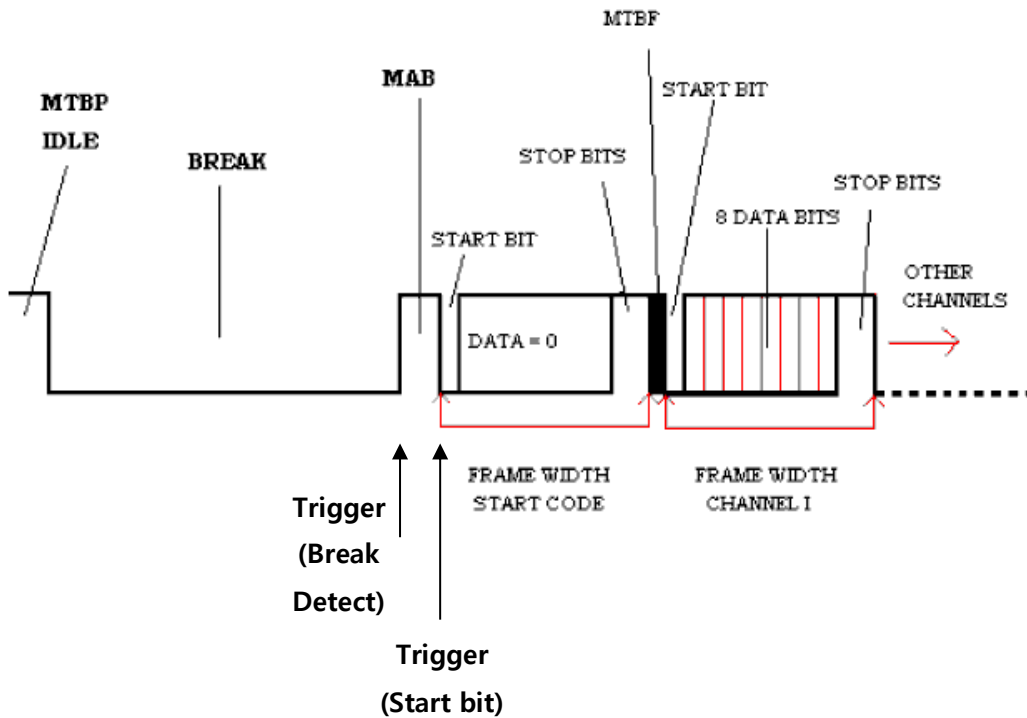

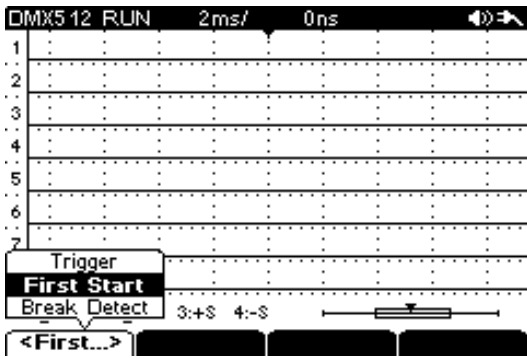

### [ 1-Wire ]

Analyze type 1-Wire communication Protocol. Signal lines between Meter and Hardware connected as below diagram. Left line indicates Hardware to measure and Right Line indicates Protocol Input port of the Meter. Connection between Signal and Input Channel to be fixed, Trigger Source selection is not required. For Trigger Pulse event, Trigger Level can be adjusted AUTO or MANUAL mode.

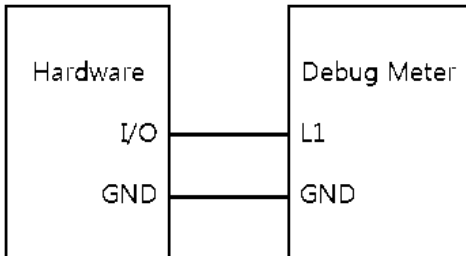

[1-Wire Signal Line Connection]

After Signal Lines are connected, select the Sub Menu Horizontal (F1), Trigger (F2) to set basic condition for 1-Wire Protocol analyzer. Then, press “F4” condition key and set all conditions in the following Sub Menu’s “F1 ~ F4” in order. After all settings are completed, press the “HOLD/RUN” key on the Meter to start Analysis.

1-Wire	F1	F2	F3	F4
	Trigger	Baud Rate		
	First Start	15.4 k		
	Reset Detect	125 k		
	Presence Detect			

Before Trigger, press the “F2” Key to select Baud Rate. There are 2 kind 15.4 k/125 k Baud Rate. Press the “F1” Key to select the Trigger Mode. As below table, there are 3 selections - Reset Detect (when Reset Period ending), Presence Detect (Presence Period ending) and First Start (First Data Transmission start)

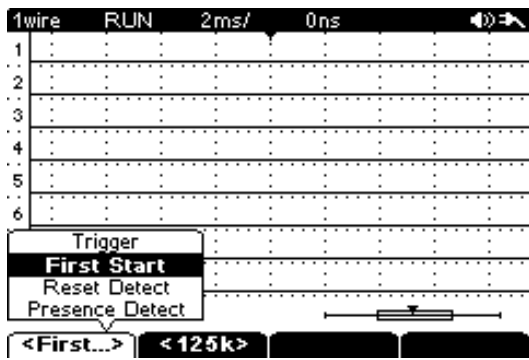
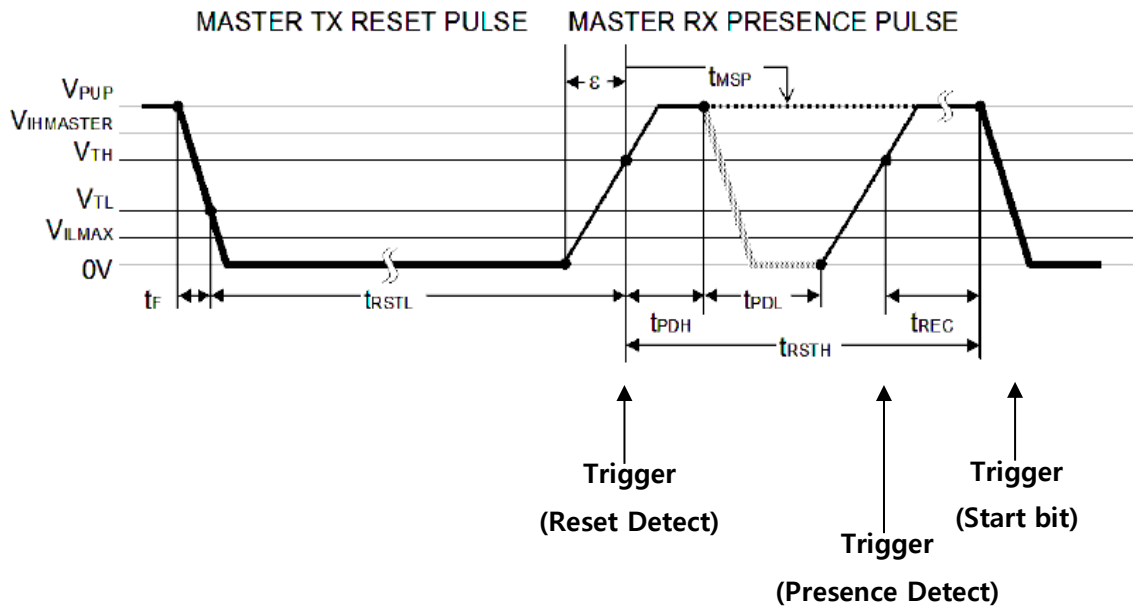

# Pattern Generator

The meter contains an internal Pattern Generator function which generates and transmits Signals outputs through TX channels. With this, the Pattern Generator can be used to test exterior systems. It can also receive Exterior Signals through the RX channels.

It also can capture RX/TX signals simultaneously which enables Waveform display in Window Screen of Meter. To do this, User need to select Trigger Source RX/TX and set Trigger Conditions from the Menu's.

Data, Information captured through RX/TX signal lines can be displayed on window screen in Text format. On the Waveform Window, Signals are displayed only when they satisfy the Trigger Conditions. In order to set the Values and Format of the Pattern Generator, use the Message Window. Supporting Pattern type: standard UART, CAN and User Defined Patterns (Signal speed and Frequency of each pattern can be adjusted).

## [Major Specifications]

Channel : TX(Output), RX(Input) 2 Channel

Logic Level : 3.3V CMOS Level Fixed, Positive/Negative Logic Output

Pattern :

- Supports asynchronous serial pattern format of UART, CAN and User defined digital patterns.
- Possible to set configuration of Multiple Sending and Interval setting.

Rate: Max. 1 Mbps

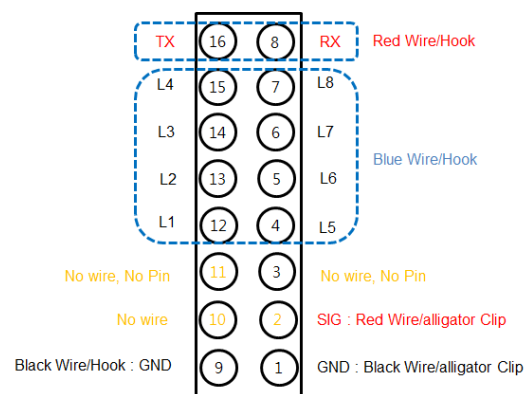

[Logic Cable]

Pin No	Function	Pin No	Function
1	Ground(Black/Clip)	9	Ground(Black/Hook)
2	Signal out(Red/Clip)	10	N/A
3	N/A(pin cutting)	11	N/A(pin cutting)
4	Logic5(Blue/Hook)	12	Logic1(Blue/Hook)
5	Logic6(Blue/Hook)	13	Logic2(Blue/Hook)
6	Logic7(Blue/Hook)	14	Logic3(Blue/Hook)
7	Logic8(Blue/Hook)	15	Logic4(Blue/Hook)
8	Pattern Generator RX(Red/Hook)	16	Pattern Generator TX(Red/Hook)

**[Signal Line connection]**

RX signal connect with Hook Number # 8 (RED) of Logic Cable. TX Signal connect with Hook number 16 (RED) of Logic Cable. In order to display Signals in the Window, use the common CH1/CH2 of Logic Channel,

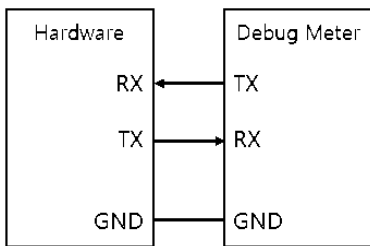

**[Functions and structural element]**

- Monitoring elements: Transaction Window, Waveform Window, Message Window.
- Configuration elements: Message Setup, Condition Setup.
- Control elements: Output (Message sending ON/OFF control)
- Hold key on Meter (Waveform or Transaction Start/Stop control)
- Save/Recall key on Meter (Waveform/Transaction storage)

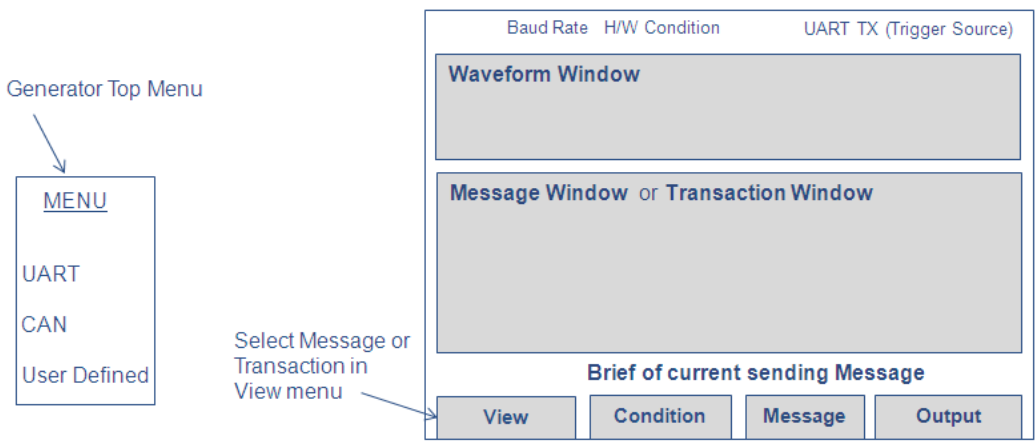



Monitoring elements allow the observation of the contents of the Transmit signal or User Defined signal. Configuration elements define the contents and format of the output message or to set hardware conditions and other necessary requirements.

Control element is to control Message Sending On/Off and signal flow of exterior Hold/Run, Save/Recall keys on the meter.

To enter the "Pattern Generator" Function, press main function key "PATTERN" and press "MENU/User" key to select the Pattern Type. Select the Conditions in the Sub Menu (F2 key) and Message Set up in the Sub Menu (F3 key) and then select the View Mode (F1 key). In View mode (F1), you can select Message or Transaction. Press the "F4" key to select OUTPUT "ON" to begin Signal Output. Can monitor Input / Output signals. At bottom line of Window screen, Summary Message regarding present transmit signal is Main Menu summarized as below.

P/G (Common)	F1	F2	F3	F4
	View	Condition	Message	Output
				OFF ON

**[Procedure]**

Pattern Generator operation procedure is as follows;

- Press Major Function key "PATTERN"  to enter Pattern Generator Mode.
- Press Menu key to select Pattern type (UART, CAN, user Defined).  
Press "F3" Message key to set Signal Value, Format, number of iterations, time interval and save.
- Press "F2" Condition key to select Trigger Condition, Baud Rate, Cursor,
- Press "F1" key to select View Mode
- Insert Logic-Pattern plug to Logic-Pattern Input Terminal at right side of the Meter.
- Connect RX/TX Hook of Logic-Pattern Cable to the Signal Lines.
- Press "F4" Output key to "ON". Then Signal Output.
- When needed, press "Hold/Run" key on the Meter to hold the display on the meter.  
To save Measurement Data, press "Save/Recall" key.

**[Detail Menu Set]**

The below table explains Messages, Conditions menu settings by Pattern Type. All Pattern Types have a similar structure in general, there are little differences in structure of Baud Rate, Message Format and Data.

**[UART]  
Message Setup**

Message	F1	F2	F3	F4
	Memory	Format	Data	Cycle
	1 ~ 8	Data Bit Parity Bit Stop Bit	Data Bit Length Data Value	Interval Repetition

- F1 (Memory): Set Format, Data and Cycle Values and select the memory address to save. After address selected, press ENTER key on the Meter to complete SAVE.
- F2 (Format): Set Length, Parity value, Stop bit length of UART Data bit (8-bit fixed).
- F3 (Data): Set Value and Length of Data to send.
- F4 (Cycle): Set Number of iterations in Repetition and time interval in Interval.

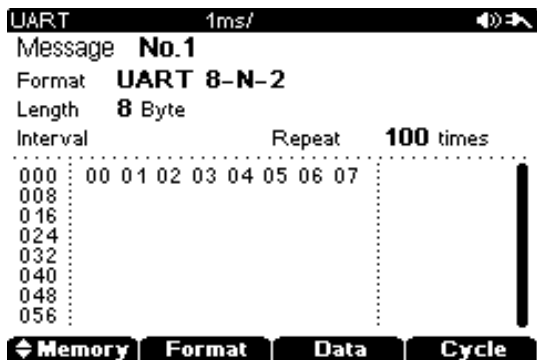

**Condition Setup**

Condition	F1	F2	F3	F4
	Trigger	Trg. Level	Baud Rate	(Blank)
	Source	Auto	2400 b/s ~	
	Signal Type	Manual	921600 b/s	

- F1 (Trigger): Capture the Signal. Set Trigger Condition to display. Similar to UART setting of Protocol Analyzer,
- F2 (Trg. Level): Select Trigger Level by Auto or Manual.
- F3 (Baud Rate): Select Baud rate of Signal to send.

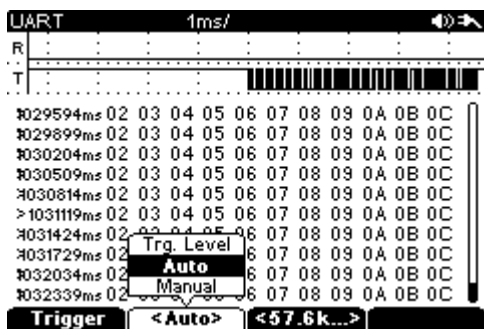

## View Setup

View	F1	F2	F3	F4
	Information	Acquire	Cursor	Clear
	Message	Auto	OFF	
	Transaction	Normal	X1	
		Single	X2	
			X1/X2	
			Tracer ON	

F1 (Information): Select the information to display under the Waveform area of the screen.

F2 (Acquire): Select the Acquisition mode to acquire waveform Data.

F3 (Cursor): Select the Cursor Function on the Waveform area of screen.

F4 (Clear Window): Use to clear the accumulated information data in Transaction mode

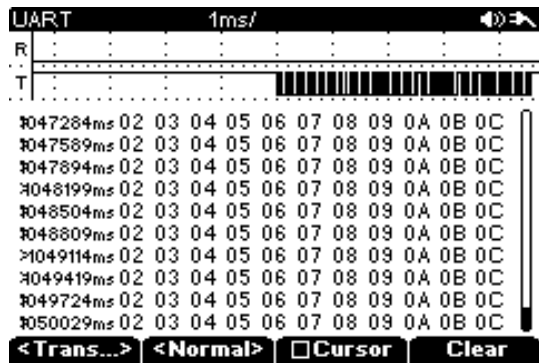

## [CAN]

### Message Setup

Message	F1	F2	F3	F4
	Memory	Format	Data	Cycle
	1 ~ 8	Standard Type	ID	Interval
		RTR	DLC	Repetition
			Data Value	

F1 (Memory): Set Format, Data and Cycle Value and select the memory address to save. After address selected, press ENTER key on the Meter to complete SAVE.

F2 (Format): Select Standard Type of CAN and Type of Frame to send.

F3 (Data): Set ID of Data to send. DLC and Value of Byte,

F4 (Cycle): Set Number of iterations in Repetition and time interval in Interval.

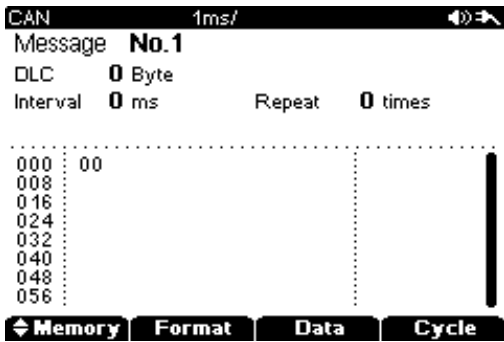

### Condition Setup

Condition	F1	F2	F3	F4
	Trigger	Trg. Level	Baud Rate	(Blank)
	Source	Auto	10 kb/s ~	
	Signal Type	Manual	1 Mb/s	

F1 (Trigger): Capture the Signal. Set Trigger Condition to display. Similar to the CAN settings of the Protocol Analyzer.

F2 (Trg. Level): Select Trigger Level by Auto or Manual.

F3 (Baud Rate): Select Baud rate of Signal to send.

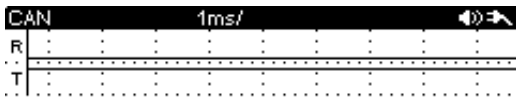

### View Setup

View	F1	F2	F3	F4
	Information	Acquire	Cursor	Clear
	Message	Auto	OFF	
	Transaction	Normal	X1	
		Single	X2	
			X1/X2	
			Tracer ON	

F1 (Information): Select the information to display under the Waveform area of the screen.

F2 (Acquire): Select the Acquisition mode to acquire waveform Data.

F3 (Cursor): Select the Cursor Function on the Waveform area of screen.

F4 (Clear Window): Use to clear the accumulated information data in Transaction mode

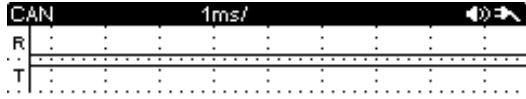

**[User Defined]**

**Message Setup**

Message	F1	F2	F3	F4
	Memory	Format	Data	Cycle
	1 ~ 8	Idle Value Polarity	Data Bit Length Data Value	Interval Repetition

F1 (Memory): Set Format, Data and Cycle Value and select the memory address to save. After address selected, press ENTER key on the Meter to complete SAVE.

F2 (Format): Select Value (0/1) at Idle Condition in User Defined Pattern and select Polarity (Normal/Inverted) when Pattern output.

F3 (Data): Set Length and Value of Data to send. .

F4 (Cycle): Set Number of iterations in Repetition and time interval in Interval.

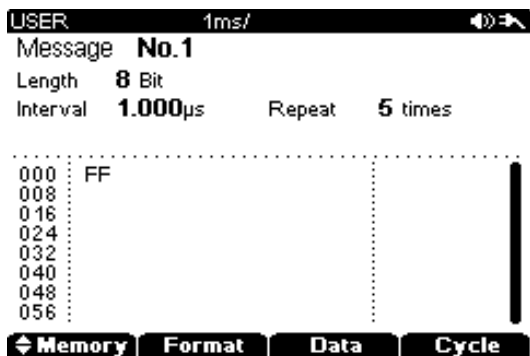

## Condition Setup

Condition	F1	F2	F3	F4
	Trigger	Trg. Level	Baud Rate	User Baud
	Source	Auto	2400 b/s	1 b/s
	Signal Type	Manual	...	...
			1 Mb/s	1 Mb/s
			User Defined	

F1 (Trigger): Capture the Signal. Set Trigger Condition to display. Similar to UART setting of Protocol Analyzer,

F2 (Trg. Level): Select Trigger Level by Auto or Manual.

F3 (Baud Rate): Select Baud rate of Signal to send. Can select among Standard Baud Rates being generally used or User Defined.

F4 (User Baud): When User Defined selected in F3, Can select User Defined Baud Rate, Can change baud rate with Direction Key on the Meter.

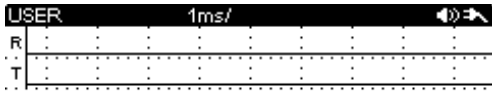

## View Setup

View	F1	F2	F3	F4
	Information	Acquire	Cursor	(Blank)
	Message	Auto	OFF	
		Normal	X1	
		Single	X2	
			X1/X2	
			Tracer ON	

F1 (Information): Select the information to display under the Waveform area of the screen.

F2 (Acquire): Select the Acquisition mode to acquire waveform Data.

F3 (Cursor): Select the Cursor Function on the Waveform area of screen.

USER 1ms/   
R  
T

Information  
Message  
**Transaction**  
  
<Trans...> <Normal>  Cursor Clear

## Signal Out (方波)

The meter can output a Square wave which can generate PWM (Pulse Width Modulation) generation or supply a Synchronous clock signal (Transmission Speed generator). This function allows for checking and calibration of Water Flow Meter display, Counter, Tachometer, Oscilloscope, Frequency converter, Frequency Transmitter and other Frequency Input Devices.

Signal Output	F1	F2	F3	F4
	▲▼ Freq	◀▶ Duty		

### [Signal Output]

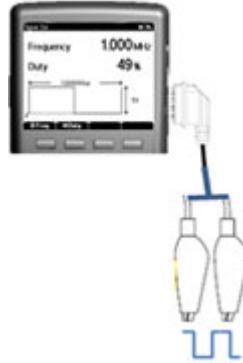

① Select main function  key .

- Press sub menu F1 frequency to change Frequency Output
- Press F2 Duty to change Duty of Frequency Output

- Output Frequency: 5Hz ~ 1000kHz
- Duty : 5% ~ 95%
- Output level : 3.3V

1) To Adjust the Frequency Output

- Press the sub menu "F1" key to set Output Frequency
- Use the UP/DOWN directions keys to adjust the value.
- Frequency is displayed on main display.
- Minimum Changeable Resolution is 1Hz.
- Default Frequency Output set up at 1kHz.

2) Output Duty Cycle Change

- Press the Sub menu "F2" key to set Duty Cycle (%).
- Use the UP/DOWN directions keys to adjust the value.
- Duty Adjustable Range 5% ~ 95% by 1% step.
- Initial Duty Set up at 50%.

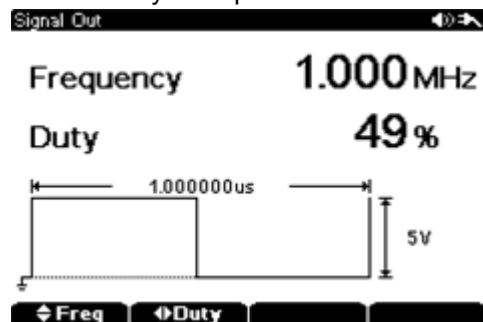



### 3. MEASUREMENT SECONDARY FUNCTIONS

- Data Logger
  - Data Logger Set Up
  - Start Recording Start
  - Recording Stop
  - Recall
  - Zoom
- Data Save, Recall, Erase
- Hold(Data Hold, Auto Hold)
- dBm Display
- USB PC Communication
- Relative measurement
- Peak Detect
- Limit
- Max/Min

#### □ Data Logger

The meters data logging function can collect measured data and save the results for diagnosing trends and events over long periods of time. The logging feature works on Voltages, Currents, Resistance, Capacitance and AUX measurements (Temperature, High Currents, Relative Humidity and Pressure)

Measured data is saved in the internal memory of meter which is stored even if the Data Logger is power off or the battery is replaced. While Data logging, the data includes Min, Max, Average data and the logged data records can be recalled on the meter display through the Recall function or on the PC through PC interface software program.

Logged Data includes Logging Time information which consists of Sampling Time, Min/Max value detection time, logged data is accumulated from Start to Stop.

The Data Logging function has a 3 step menu, Logging Setup Menu, Active Logging Menu, and Logging Review Menu.

Main Menu	F1	F2	F3	F4
	▲▼ Sampling	RUN Time	Start	Exit

**[Menu – Logging Setup]**

Logging	F1	F2	F3	F4
				Stop

**[Menu - Active Logging]**

Stop	F1	F2	F3	F4
	▲▼Zoom	Pan	Save	Start
		Cursor		

**[Menu - Logging Review]**

**[How to Operate]**

- First: Select “Voltage”, Current, Resistance, Capacitance or AUX” from the Main Menu.
- Second: press “Logger”  key to enter Data Logging function.
- Set “F1” Sampling rate and “F2” RUN time in sub menu.
- After set up, press “F3” (Start) key to start Data Logging.
- Data Logging is to achieve measured data for the desired time period. To minimize error during Data Logging, all keys (except Power On/Off key, Data Logger Sub Menu keys) are disabled during Data logging.
- While the Data Logger is running after set up, Automatic Power Off function is also de-activated.
- To stop Data Logger function when Data Logger in running, press the “F4” (Stop) key in the Sub Menu.

**[Note]**

Data Logging stops when

- Data Logging (Running) preset time is over.
- Data Logging data exceeds the Internal Memory Capacity.
- Battery Drains completely when Battery is the only power supply.

**1) Data Logger Set Up**

Factory defaults below will be used if not changed during logging setup.

- Sampling Time : 1s
- RUN Time : 10,000s
- Max Sample Data : 10,000 records

Main Menu	F1	F2	F3	F4
	▲▼Sampling	RUN Time	Start	Exit

**[Menu Logging Setup]**



- **Sampling Time (Logging Interval Time) :**

The Sub Menu to set up data Logging consists of “F1”(sampling), “F2”(Run Time), “F3”(start), “F4”(Exit) as above.

- Press the “F1” (sampling) key and adjust the value with the up with Up/Down directional keys.
- The Internal Memory size is fixed. Adjustment of the (Sampling) and (Run Time) settings will determine the maximum number or recorded data's that will fit in the memory. Priority for Sampling or Run Time is determined by which setting is programmed first.
- Sampling Time (Logging Interval Time) : can be variable 1s ~ 60s
- Sampling Quantity : Interval (Max 10,000), Event(Max5,000)

- **Run Time :**

Data Logging Total Running Time can be set up to a maximum of 10,000 data sampling points due to the limit of the internal memory capacity.

- Press “F1” Key to set SAMPLING TIME, then Maximum Sampling time can automatically be calculated.
- Press “F2” key to reduce Maximum Sampling Time with Up/Down keys. Maximum Sampling Reduction is available but Maximum Sampling Increase is not available.

## 2) Logging Start

After parameters are set, press the “F3” (Start) key to begin data logging. While Data Logging is active, all sub menus disappeared except “F4” (Stop) and All sub Menu keys are inactive except the “F4” (Stop) key.

	F1	F2	F3	F4
Logging				Stop

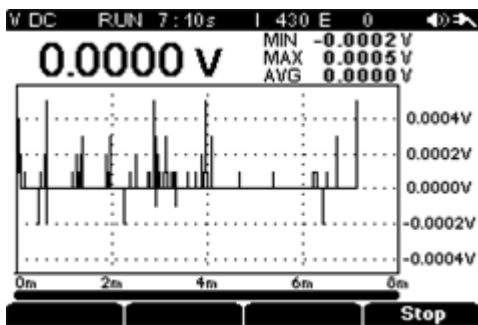

## 3) Logging Stop

Data Logging ends when the Sampling Time setting is reached, the battery is completely discharged, or when the “F4” (STOP) key is pressed.

- After Logging is completed, the data can be reviewed or saved. Or Logging can be exited.
- During Data Logging, if the “F4” (Stop) key is pressed, Sub-menu ZOOM or SAVE is displayed.
- To save Data Logging Data, press “F3” (Save). The meter then switches to the save menu and results can be saved in order in a separate Memory Area.

- If any key is pressed without saving the Data, A warning message appears to prompt whether to SAVE or NOT. If the user still does not press “F3” (Save), the data will be lost.
- To restart Data Logging after the Save function, press “F4” (Start) key again.

Stop	F1	F2	F3	F4
	▲▼Zoom	Pan	Save	Start
		Cursor		

[Stop Menu]

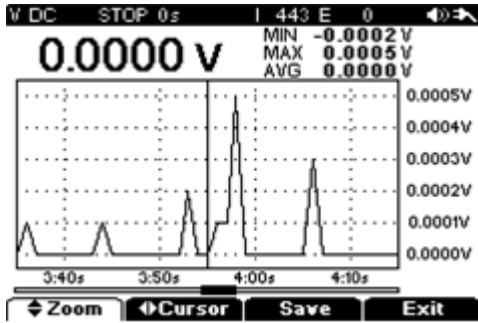

#### 4) Recalling Saved Data

Saved Data is saved in regular intervals which displays as a Strip Chart Recorder. To recall Data when Data Logging is stopped or from any other function in progress, Hold the  key longer than 2 seconds. Recall is not available while actively Data Logging.

Save/Recall/Erase	F1	F2	F3	F4
	Mode	▲▼Slot	Recall	Save
				Erase

[Save, Recall Initial Menu]

Recall	F1	F2	F3	F4
Recall	▲▼Zoom	Pan		Exit
		Cursor		

[Save, Recall Review Menu]

- Hold the  key longer than 2 seconds to see “F1” (Mode), “F2” (Slot) initial recall menu.
- Press “F3” (Recall) key, to open the Data Log (Recall) mode, and show Saved Location slots.
- Select the data to recall using the Up/Down keys.
- When the data is selected, press the “F3” Recall Key. The selected data is shown on the Display.
- Pressing “F3” Recall Key again will change the menu to the Zoom menu

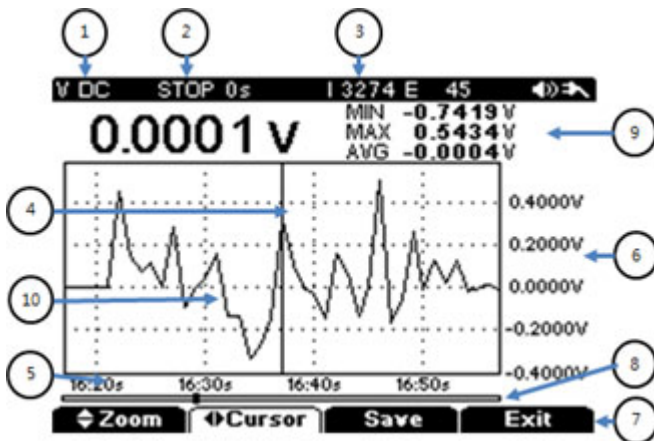
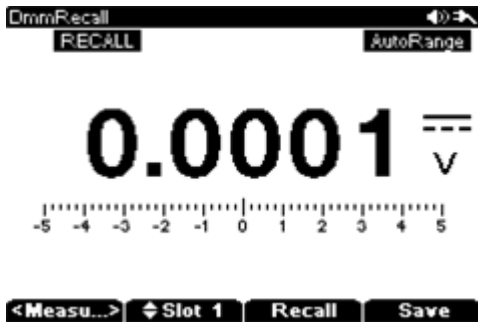

No	Description
1	Data Logging Function
2	Logging Mode(RUN or STOP)
3	Data Sampling Number
4	Cursor
5	Time Scale(Horizontal)
6	Voltage Scale(Vertical)
7	Sub-Menu
8	Time Bar
9	Measure Value(Min/Max/Avg)
10	Trend Line

## 5) ZOOM

Logged Data is accumulated continuously and saved during Data Logging. To review data in a specific period, the user can zoom the Data in "STOP" mode.

Stop	F1	F2	F3	F4
Stop	▲▼Zoom	Pan	Save	Start
		Cursor		

### [Data Logging Stop menu]

[How to operate]- While in STOP mode.

- When Data Logging is active, press "F4" (Stop) key to pause the data logging. Press Sub Menu "F1" key to Zoom the Data.
- Use "F2" Cursor key (Left/Right) to expand the area to observe.
- Press "F1" Zoom key and set Zoom with up/down keys (Expansion ▲(up) up to the minimum Time Ratio. Decrease with ▼(down) key.
- To review the specific area again, press "F2" PAN key and select the area to review again with Left/Right direction key and check Trend Data.

Recall	F1	F2	F3	F4
	▲▼Zoom	Pan		Exit
		Cursor		

### [Recall Menu]

[How to operate]- From the Recall mode

- At Initial Save/Recall screen, select the address to Recall and press the "F3" (Recall) key.
- Press Recall key to see the Recall sub- menu as in above.
- Press "F2" (Cursor) key and select zoom area to observe with Left/Right key.
- Press "F1" (Zoom) key to set Zoom Ratio with Up/Down keys.
- To review the specific area again, press "F2" (PAN) key and select the area to review again with Left/Right directional keys.

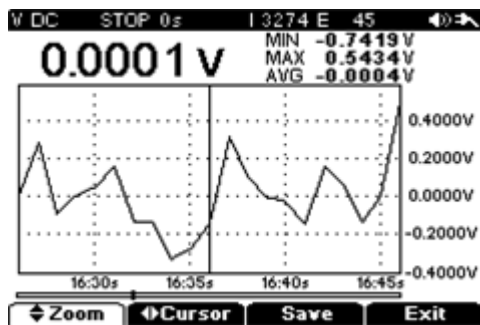

### [ZOOM]

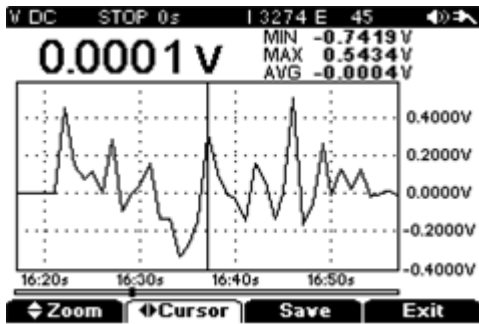

[Cursor]

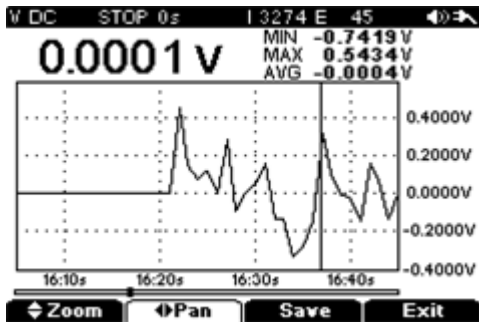

[PAN]

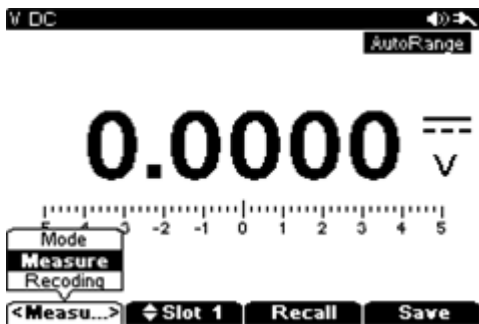

[Save/Recall Initial Screen]

## □ Saving Data

All measurement data from meter functions can be saved by pressing the Data Hold key. Data is saved as a Snap Shot taken in Hold mode.

- Press  key longer than 2 seconds. The Save/ Recall initial menu (Save, Recall) comes up.
- Press “F1” (Mode) key then convert to data (Save) mode. Press “F1” (Mode) key to save “snap shot” or recording (Logging).
- Press “F2” key in Save mode and select Saved Area Location Address with Up/Down key. When a Save with Address is not selected, Data will be saved in the next open slot in file.
- If address is selected, press “F4” (Save) Key to save the data at the assigned address.
- Press “Menu” key to return to previous Measurement mode.

□ Measuring (snap shot) or Recording (Logger Data) are available in 10 separate locations.

- When all addresses are full, the meter will start over to Save in slot number 1. At this time, the meter will display a warning whether the user will erase the old data in slot number 1.

Save/Recall/Eraser	F1	F2	F3	F4
	Mode	▲▼Slot	Recall	Save
				Eraser

**[Save, Recall Initial Menu]**

**[Recall-Snap Shot]**

Snap Shot saved in Internal Memory of Meter can be recalled for viewing.

- Press  key for longer than 2 seconds, initial menu (Save, Recall) will appear.
- Press “F3” (Recall) key to enter RECALL mode.
- Press “F2” (Slot) key and select Recall Data address with Up/Down keys
- After the address is selected, press “F3” (Recall) key to recall the Data
- Press (Menu) key to return to original measurement mode.

Save/Recall/Eraser	F1	F2	F3	F4
	Mode	▲▼Slot	Recall	Save
				Eraser

**[Save, Recall Initial menu]**

Recall (Review)	F1	F2	F3	F4
	▲▼Zoom	Pan		Exit
		Cursor		

**[Recall menu]**

**[Eraser]**

Eraser Saved Data from the Internal Memory.



- Hold  key longer than 2 seconds. The menu (Save/Eraser/Recall) will appear.
- Press “F2” (Slot) key and select Eraser Data address with Up/Down key
- After Eraser data address is selected, press Eraser key to eraser the data.
- Press Menu key to return to original measurement mode.

Save/Recall/Eraser	F1	F2	F3	F4
	Mode	▲▼Slot	Recall	Save
				Eraser

**[Save, Recall initial menu]**



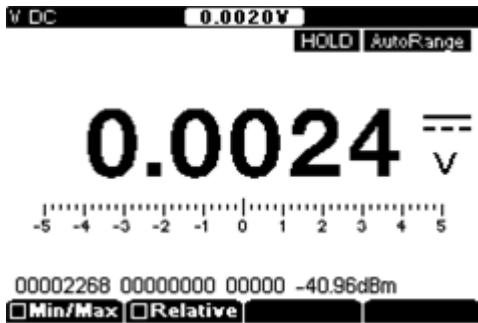

## □ Data Hold

- Press the  key to hold the Measurement data, “HOLD” is displayed in upper corner of the screen.
- Press  key again to release the “HOLD” mode.
- During “Hold” mode, present real time measurement values are displayed in upper screen portion of the display.



## □ Auto Hold

Auto Hold function is displays and updates values based on changes in value.

- Hold the  key more than 2 seconds to enter “Auto HOLD” mode.
- Hold the  key more than 2 seconds to release “Auto HOLD” mode.
- Auto Hold displayed values change when the Measurement Value deviates by more than  $\pm 5\%$  change from 1st Measurement Value displayed in auto hold mode.
- Auto Hold function is very useful to check measurement value shifts and levels during measurements.



## □ dB (decibel)

- Voltage can be displayed as dBm, relative to a value of 1 mW.
- To change the Measurement Value to dBm, select dBm in Voltage measurement mode of (VDC, VAC, or VAC+DC).
- dBm measurement is differentiated with a Reference Impedance. Therefore, you must set the reference impedance value depending on the application.

- Impedance value can be set up between 1Ω ~ 1000Ω range in User mode.
- Default value is 600Ω
- dBm unit means Wattage to deliver to Reference Resistance based on 1mW unit.
- Voltage measurement value can be converted using the following formula.

$$\text{dBm} = 10\log \frac{1000 \times (\text{measured voltage})^2}{\text{reference impedance}}$$

- Press “F3” key to activate the dBm function while measuring Voltages and press “F3” key again to release the dBm function.
- dBm value is displayed in the sub display area: lower right area of screen.
- When dBm function is activated it will display the value where duty is normally displayed.
- The dBV calculates the voltage with respect to 1V, as in the formula shown below.
- $\text{dBV} = 20\log(\text{measured voltage})$

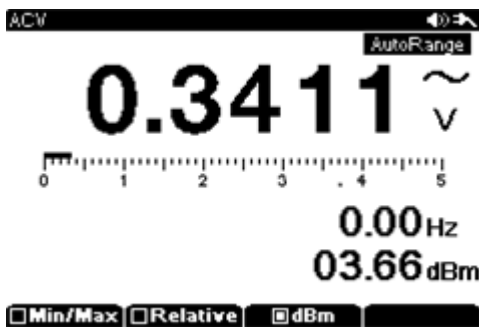

#### Relative measurement.

Relative measurements display the difference in value between the present measurement value versus the initial set up base value when entering into the relative mode. Relative measurement is available when measuring Voltage, Current, Resistance, or Capacitance.

“Relative” is in the Sub Menu for those main functions.

- Relative function is activated by pressing the “F2” (Relative) key during Voltage, Current, Resistance, or Capacitance measurements.
- “REL” is displayed in the upper center of the screen when this feature is active.
- Main Display shows Relative measurement value and the Sub display below shows the present value and initial set up reference value. All values are displayed simultaneously.
- Exiting the relative mode will revert back to the Main Menu Function.
- To restart the relative reference value, press “F4” (Restart) to refresh the reference value.

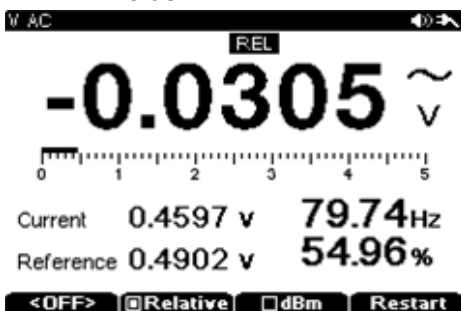

## □ Peak Detect

Peak Detect is a similar function to the MIN/ MAX functions explained earlier. The difference between Peak and MIN/MAX is response time.

Response Time of Peak function is (250µs), much faster than the MIN/MAX responds.

Because of this quick response time, the meter can measure the true peak value of Sine Waveform, Peak function can also be used to measure transient currents accurately.

- To activate Peak mode, press Sub Menu “F1” key and select (Peak)
- Main Display will show the present measurement value and the sub display shows the peak captured value with time stamp of when the peak occurred.
- If Peak Value of Input signal drops lower than MIN value recorded or higher than MAX value recorded, an audible alert sounds and a new value is recorded. After a new peak session is started, all measurement values are recorded with measurement time stamping.
- Pressing the  key, will exit the Peak Detect mode.

Voltage	F1	F2	F3	F4
	Min/Max	☐Relative	☐dBm	
	Peak			
	OFF			



[NOTE]

□ If you change the measurement function without saving the data, all collected data will be lost.

□ To store peak value, press the  (HOLD) key.

## □ Limit

This meter function is useful for setting upper and lower limit ranges for measurements for comparisons within a range.

Voltage (AC)	F1	F2	F3	F4
	Min/Max	☐Relative	Limit	
	Peak			
	OFF			

## [How to operate]

① Press the  main function key.

- Press the Menu key and select “Ohm, Continuity, Diode, or Capacitance”
- select “F3” (Limit)
- After measuring the component, the measured value is compared with the preset Low-High limits, display shows “Pass” or “Fail”.

- Limit function is automatically released when any other Sub function key or main function key is selected.

#### □ Min/Max

Min/Max mode records the Minimum, Average, and Maximum Input Values when checking Voltages, Currents, Resistance, or Capacitance. Min/Max mode is in a Sub Menu for each main function.

If Input value is lower or higher than preset values, an alert beep sounds and new measurement value is updated and recorded with a time stamp. This mode is useful when checking values generated intermittently or to record Minimum, Maximum values while user is not at the meter.

- Pressing the  (Hold) key exits the Min/Max mode.

Voltage (AC)	F1	F2	F3	F4
	Min/Max	☐Relative	☐dBm	
	Peak			
	OFF			

DMM (ohm)	F1	F2	F3	F4
	Min/Max	☐Relative	Limit	
	Peak			
	OFF			

#### [How to Operate]

- Select the Main Function Key.
- Then press “F1” Min/Max in the Sub Menu.
- Pressing “F1” will cause the upper Screen to show “Min/Max” icon and the measurement screen is changed.
- Main display shows present measurement value.
- Sub display will show Max/Min values displayed with time stamp.
- To exit the Min/Max mode, press the  (Hold) key.

#### [Note]

- While in MIN/MAX recoding mode, the meter converts to Battery Save mode to extend battery time.
- MIN/MAX is displayed in the lower portion of the Main Display with time.

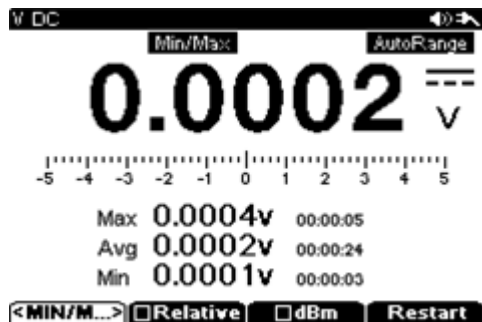

## 4. Software Installation

### USB Communication Link

- The meter features a bi-directional communication function and allows for all stored data in memory to be transmitted to a PC.
- USB Cable (standard) is supplied with the Software interface program file included in the packaging.
- Select USB in “**User**” setup Mode.
- A USB Mini Type connection socket is located on the top right side of the meter.
- Install the software and device drivers prior to connecting the USB to the PC.
- A USB communication cable is supplied as an original accessory with the meter. If using another USB cable, make sure it is of the “A-B” type.
- After installation of the PC program, pressing the HELP key button on meter will display the details about the PC Program execution.

### [NOTE]

The SBS-700 is capable of performing bi-directional communication and control of the meter via the PC on a real time basis, user can review or download the data that is stored inside of internal memory of meter as well as use the software for recording and screen capture.

### [How to install USB]

#### Driver and PC Software

- Insert the supplied CD disc into the PC
- Open the Disk Directory and Run the “SETUP” by double clicking on the icon.

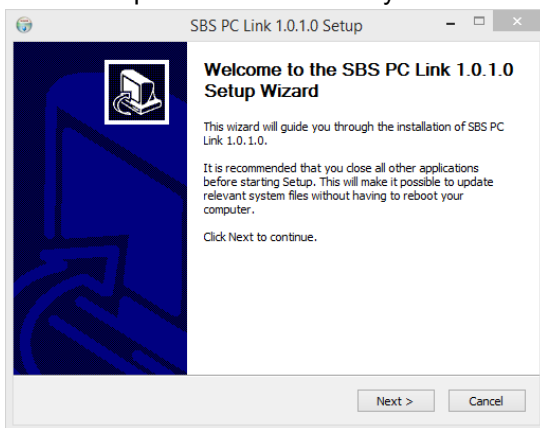

- Click “NEXT” to continue.

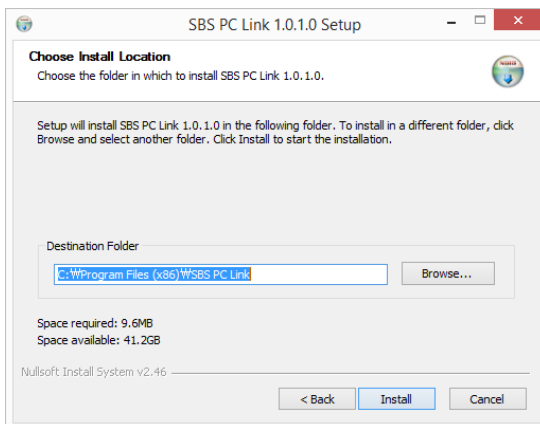

- Click “Install” to continue.

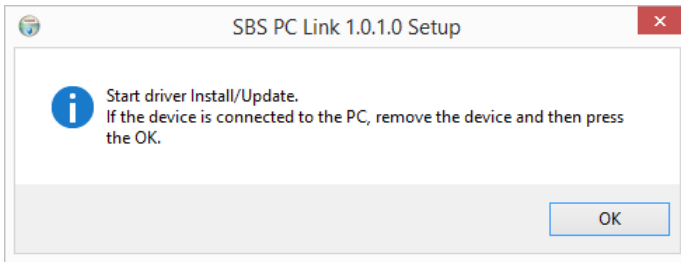
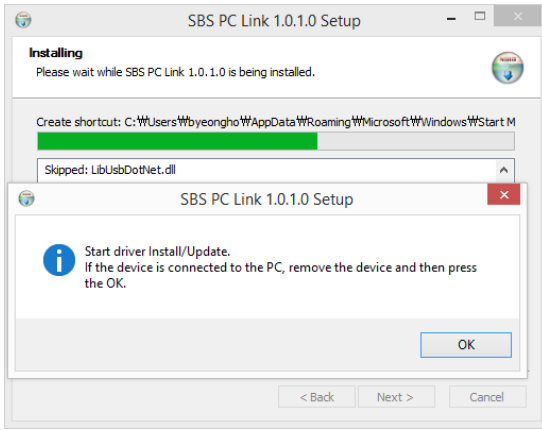

- Appear driver Install/Update message.  
If the device is connected to the PC, remove the device and then press the OK.

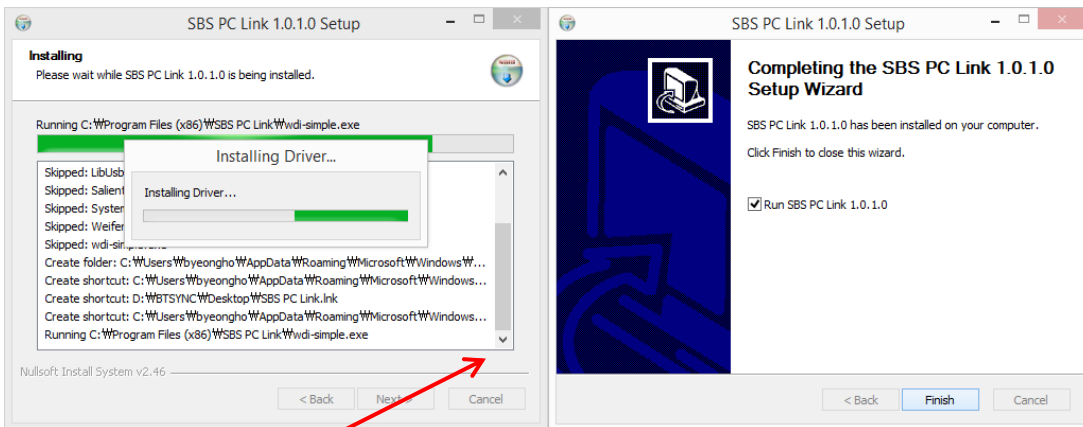

- Click "Finish" to complete the installation.  
Software and Driver installation is completed.  
Remove the installation CD from the PC.

A Desktop ICON for the SBS600/SBS700 will appear on the desktop.



### [How to RUN the PC Program]

- Power "On" Meter. .
- USB Interface connected to meter and PC USB port.
- Click the desktop ICON to launch the SBS-600/SBS-700 PC Link.

## 5. Initial Settings before use

This chapter explains the Meter's Initial Set Up and useful Option Set Up procedures.

- User Mode
- Initial Impedance Set Up to measure dBm measurement
- Beep(Buzzer) Sound Set Up
- Key Sound(MUTE)
- Auto Power Off
- Back Light OFF Time
- PC Interface ON/OFF

### □ User Mode

To enter the User Menu, hold the  (User)key longer than 2 seconds. In the User Menu, the following procedure can be used to Set Up meter defaults. Click Menu to set up or change. Change the menu with “▼▲, ►◀” keys.

Press  key to complete Set Up or Change.

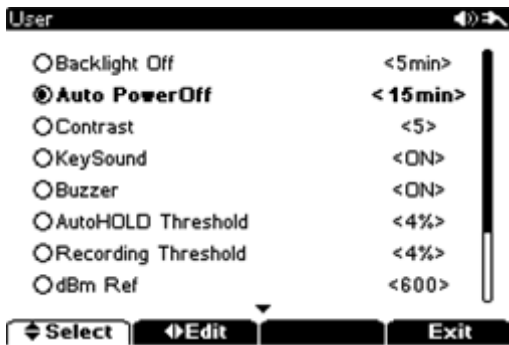

### [Select Menu]

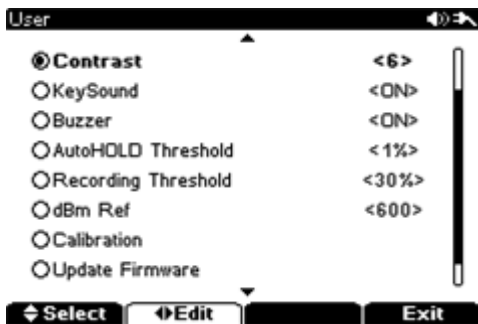

### [Edit Menu]

## Factory Default settings / Options

Function	Factory Setting	Setup Options
Back Light	ON	ON(10minute), OFF
Auto Power	OFF	ONOFF, 5m ~ 240minute
LCD Contrast	50	30 ~ 70 Adjust
Key Sound	ON	ON, OFF
Beep Sound	ON	ON, OFF
Auto hold Threshold	4%	1%~30%
Recording Threshold	4%	1%~30%
dB Reference	600Ω	2, 4, 6, .....1200
Calibration	OFF	ON, OFF
Update Firmware		
Device Information		
USB Interface	OFF	ON, OFF
Help Language	English	English

### Initial Impedance Set Up for dBm measurement

Impedance to measure dBm can be set up within the range of 1 ~ 1200Ω.

Factory preset value is 600 Ω.

### Beep(Buzzer) Sound Set Up

This mode controls the sound during Continuity Test.

This mode can is set to ON or OFF in the User Menu.

[The WARNING sounds for input Over Voltage or battery power low warnings are set up with the "TONE" setting which is a different set up procedure than the above Continuity sound.]

### Key Sound(MUTE)

This mode toggles the Function key sound when Pressing "Function" keys.

This mode can is set to ON or OFF in the User Menu.

### Auto Power Off

User can select the APO (Auto Power Off) time in the range from 10minute~60 minutes

User can select 10, 15, 20, 30, 45, 60min, or OFF.

With the APO timer active, the Meter will be automatically power off after the set amount of time unless any of following events occur.

- Pressing any function key or menu key.
- Change of measurement function.
- Data Logging is Active
- Peak Hold is Active
- APO is disabled in the User Menu.
- To turn the meter on from APO after Power is Off, press any key on the meter.
- To disable APO function, select OFF in the User Menu.



**Back Light OFF Time**

Back Light on timing can be set up in the range from 1minute ~ 60minutes by minute unit steps with the "F2" (Edit) Key or UP/DOWN keys. Default setting time is 10 minutes.

**PC Interface ON / OFF**

PC Interface can be set to ON / OFF in the User's Menu.  
Default Mode is ON.

**LCD Contrast**

Adjusts the LCD display brightness to the measuring environment conditions.  
Adjust Level range from 1~10. Lower number makes screen brighter, higher number becomes darker.  
Factory Default setting is at "5".

**Auto Hold Threshold**

Auto Hold is the feature that data is automatically held on the display when it exceeds the preset level compare to the Initial value.  
Factory default setting level is 5%. The adjustable range is between 1 % ~ 30 % in the User Menu.

**Recording Threshold**

In Data Logging modes, it records the difference in value from the Threshold compared with previous data stored.  
Factory default setting level is 5%. The adjustable range is between 1 % ~ 30 % in the User Menu.

**Calibration**

Calibration Mode of Meter is available in the User Menu.

**Firmware Update**

Future Firmware Updates can be completed using the following Procedure:

Select (Update Firmware) in the User Menu.  
Download the Updated Firmware to the PC  
Connect the USB Cable between PC and the Meter  
Press "Enter" key on the Meter.  
When the Update is finished, the message "Finish" will be displayed on the screen.

**System Information**

Meter System Information is listed in the User Menu.  
System information includes Model, Firmware version, Results of last Self calibration.

**Language**

Display Text is written in English.

## □ Help

Press the  (Help) key will bring up brief Information about the active Function on the display.

Help Information pages can be scrolled up/down with ▼▲ keys.

Select the Help Language after pressing the  key.

## □ Battery Save

This mode minimizes Battery power consumption during long duration use of meter in Data Logging mode. When Battery Save mode is activated, all functions including Display and any features not related to Data Logging are shut off. Battery save function starts 10 minutes

after Data Logging begins, to see the Display, press the  key.

When Battery Save mode is active, Auto Power Off function is disabled.

## 6. Maintenance

This chapter explains the basic maintenance of the meter.

- General Maintenance
- Battery Replacement
- Battery Charging
- Fuse Replacement

### [Note]

Troubleshooting beyond that specified in this manual is only to be completed by an authorized repair center.

#### □ General Maintenance

Wet or Dusty Input Terminals could cause incorrect measurement readings.

Cleaning procedure is as follows.

- Power off the Meter and remove the Test Leads/Probes from the Meter.
- Turn the meter face down and remove any dust in the terminals by gently shaking the meter.
- Clean the Exterior Cases with soft detergent or wet cloth. Do not use Solvents or any abrasive cleaning agents.
- Clean cotton swab wet with Alcohol may be used to clean out the surface of the Input Terminals.

#### □ Battery Replacement

### [Note]

When Battery low signal is blinking, replace the batteries as soon as possible.

- If Battery is completely drained replace the Batteries using the following procedure.
- Remove the Protective Holster Case from the Meter.
- Remove the Battery Cover from the Rear Case of the meter.
- Replace Batteries and ensure to connect the correct polarity inside the battery compartment.
- Close the Battery Cover and re-assemble in the reverse order as above.

#### □ Fuse Replacement

If the Fuses clear due to fault or overload, the fuses can be replaced as follows;

- Power off the Meter. Disconnect Test Leads from the Meter.
- Separate the Battery Cover from the meter.
- Pull out one end of defect Fuse from Fuse Clip.
- Replace with same size and ratings as the original fuse.. Fuse should be placed in center of Fuse Clip and pressed into place.
- Do not touch any other components besides the fuse.
- Re-assemble the Battery Cover on the meter
- Fuse Ratings and Dimensions are as below ;

### [Fuse Rating and Dimensions]

- 500mA/250V 5mm × 20mm (FF)
- 10A/250V 6.3mm × 32mm (FF)

□ Open Fuse Test

Select main menu "Resistance" key. Insert Test Leads into Resistance Input Terminals. Test Lead Tips Connected to 10A Input or mA Input to check the Fuse Open status.

- 10A:  $0.00\Omega \sim 0.50\Omega$  measurement
- mA:  $100\Omega \pm 1\Omega$  measurement.

## 7. Functional Test and Calibration.

This chapter introduces Performance Testing and Calibration procedures. Performance Test Procedure verifies the meter performs in accordance with the specifications of the meter. Calibration procedure ensures that the meter performs correctly according to specifications until next calibration time.

- Description of Calibration
- Recommended Calibration Test Equipment.
- Basic Performance Test
- Test points
- Calibration points.

### □ Calibration Description

This manual contains the procedure to check the performance of meter to determine if calibration is needed.

Calibration of the meter does not require the case be opened and does not need calibration on passive components. Meter calculates calibration coefficient parameters based on input base signal. Calibration Coefficient values are kept in the internal memory until next calibration time.

### [Calibration Cycle]

Calibration is generally recommended once per year. Product accuracy is guaranteed only when calibration is regularly conducted. If 1 year Calibration cycle is not kept, the meters accuracy can't be guaranteed.

### [Suggestion on Calibration]

Meter specifications are guaranteed within the period from the last calibration until next calibration time. Calibration needs to be completed for all functions to meet the specifications of meter.

### □ Recommended Test Equipment

The following is the recommended Test Equipment for Performance Test and Calibration procedure. If below Equipment is not available, use alternative equivalent test equipment.

Area	Recommended Test Equipment	Accuracy
DC Voltages	Fluke 5520A	under 20 % of Accuracy of meter
DC Currents	Fluke 5520A	
Resistance	Fluke 5520A	
AC Voltages	Fluke 5520A	
AC Currents	Fluke 5520A	
Capacitance	Fluke 5520A	
Diode	Fluke 5520A	

### □ Basic Performance Test

Basic Performance Test checks the basic functionality of the meter. Failure of the Basic Performance Test indicates the need for a complete calibration of the unit.

### □ Consideration Points

Long Test Leads can act as an Antenna and capture AC Signal noises.  
Best results are achieved when the following conditions are met.

- Check whether measurement is stable within Adequate Environmental Temperature 18°C~28°C range. Calibration is recommended at 23°C ± 1°C.
- Environment Relative Humidity below 80%.
- When connect V and COM input terminals with Plugs, allow a minimum of 5 minutes warm up time.

The Meter can perform very accurate measurements which require special care and attention to errors during standard calibration procedures and performance test procedure. Please be sure that the Calibrator units output is correctly at "0" when calibration for DC Voltage, DC Currents, and Resistance.

#### □ Input Connection

Connection between the Calibrator and the Meter is recommended using minimum length shielded Coaxial Cables. Cable screening strands must be grounded.

This is recommended to ensure minimum noise and stabilized performance during the calibration procedure.

#### □ Calibration Precautions

To accurately calibrate the Equipment, the following points are to be compared to output reference signals in their best conditions.

- Before calibration, allow the equipment a minimum of 5 minutes warm up time to stabilize.
- During Calibration, a low battery warning could cause a calibration error. The calibration procedure should only be conducted with a fully charged or new battery in the meter.
- Allow the meter and the Calibration unit to adjust to the same ambient temperature.

#### □ Calibration procedure

Meter Calibration procedure is as follows;

- Hold  "USER" Mode key longer than 2 seconds to enter the User Menu.
- Select "Calibration" in Menu.
- Select Calibration function to calibrate (DC/V, AC/V, DC/A, AC/A, Resistance, etc.)
- Connect reference Signal from the Calibrator to the Meter and observe the display.
- Press "Start" key on the Meter.
- While adjustment is in progress, the right upper screen shows the symbol "CAL". If the value is within the allowable range, "PASS" will come up momentarily and Calibrator advances to the next calibration item. If the value is out of the allowable range, Error Code is display for 3 seconds and the unit remains at the present calibration step. In this case, check the input value was correctly applied.
- To continue calibration of the other functions, select the next calibration item and repeat the above steps of the procedure.
- When all of the functions are calibrated, press "Enter" key to complete Calibration process.
- Power the meter first "Off" and then "On". Then return to normal measurement mode.

## 8. Specifications

### □ Electrical Specifications

#### Oscilloscope .

- Oscilloscope Bandwidth: 10MHz
- Sampling: 50MS/s
- Channel: 1channel
- Input Impedance:  $1M\Omega \pm 1\%$
- Input Capacitance:  $20pF \pm 3pF$
- Volts/div:  $20mV \sim 100V$ 
  - Coupling: AC, DC
  - Position:  $\pm 3div(20pixel * 6division)$
  - Accuracy:  $\pm 3\%$
- Time/div:  $50s/div \sim 100ns/div$ 
  - Position:  $\pm 10div(25pixel * 20division)$
  - Accuracy:  $\pm 0.1\%$
- Trigger :
  - Mode: DC
  - Position:  $\pm 3div$
  - Accuracy:  $\pm 4\%$
- Bandwidth & rise time & overshoot
  - Rise time: 35ns
  - Overshoot: within  $\pm 10\%$
- Stop, Pan, Glitch, Auto range

#### Digital Multimeter

##### □ DC Voltage

□ Start measurement after minimum 1 minute warm up time.

□ DC Accuracy  $\pm$  (Reading % + LSD)

Function	Range	Resolution	Accuracy
DC Voltage	50.000mV	0.001mV	0.05+50
	500.00mV	0.01mV	0.025+10
	5.0000V	0.0001V	0.025+10
	50.000V	0.001V	0.025+10
	500.00V	0.01V	0.030+10
	1000.0V	0.1V	0.030+10

**□ DC Currents**

Function	Range	Resolution	Accuracy
DC Current	500.00 $\mu$ V	0.01 $\mu$ A	0.05+10
	5.0000mA	0.0001mA	0.05+10
	50.000mA	0.001mA	0.15+10
	500.00mA	0.01mA	0.15+10
	10.000A	0.001A	0.30+10

**□ AC**

□ Start measurement after minimum 1 minute warm up time.

□ True RMS AC Voltage, Accuracy  $\pm$  (reading % + LSD)

Range	Resolution	Accuracy				
		20Hz~45Hz	45Hz~1kHz	1kHz~5kHz	5kHz~10kHz	10kHz~30kHz
50.000mV	0.001mV	2.5+60	1.0+50	1.0+50	1.5+50	5+50
500.00mV	0.01mV	1.5+60	0.4+50	0.4+50	0.75+50	3+50
5.0000V	0.0001V	1.5+60	0.4+50	0.4+50	0.75+50	3+50
50.000V	0.001V	1.5+60	0.4+50	0.4+50	1.5+50	No spec
500.00V	0.01V	1.5+60	0.4+50	0.4+50	No spec	No spec
700.0V	0.1V	1.5+60	0.4+50	0.4+50	No spec	No spec

□ True RMS AC Current, Accuracy  $\pm$  ( Reading % + LSD )

Range	Resolution	Accuracy			
		20Hz~45Hz	45Hz~1kHz	1kHz~10kHz	10kHz~30kHz
500.00 $\mu$ A	0.01 $\mu$ A	1.0+20	0.7+20	0.75+20	3.5+100
5.0000mA	0.0001mA	1.0+20	0.7+20	0.75+20	3.5+100
50.000mA	0.001mA	1.0+20	0.7+20	0.75+20	3.5+100
500.00mA	0.01mA	1.5+20	0.7+20	1.5+20	3.5+100
10.000A	0.001A	1.5+20	0.7+20	3+50	No spec

Current measurement max 10 A within 30 second continuous measurement.



**AC+DC**

Start measurement after minimum 1 minute warm up time.

AC+DC Voltages Accuracy  $\pm$  (reading % + LSD)

Range	Resolution	Accuracy				
		20Hz~45Hz	45Hz~1kHz	1kHz~5kHz	5kHz~10kHz	10kHz~30kHz
50.000mV	0.001mV	2.5+60	1.0+50	1.0+50	1.5+50	5+50
500.00mV	0.01mV	1.5+60	0.4+50	0.4+50	0.75+50	3+50
5.0000V	0.0001V	1.5+60	0.4+50	0.4+50	0.75+50	3+50
50.000V	0.001V	1.5+60	0.4+50	0.4+50	1.5+50	No spec
500.00V	0.01V	1.5+60	0.4+50	0.4+50	No spec	No spec
700.0V	0.1V	1.5+60	0.4+50	0.4+50	No spec	No spec

AC+DC Currents Accuracy  $\pm$  (reading % + LSD)

Range	Resolution	Accuracy			
		20Hz~45Hz	45Hz~1kHz	1kHz~10kHz	10kHz~30kHz
500.00 $\mu$ A	0.01 $\mu$ A	1.0+20	0.7+20	0.75+20	3.5+100
5.0000mA	0.0001mA	1.0+20	0.7+20	0.75+20	3.5+100
50.000mA	0.001mA	1.0+20	0.7+20	0.75+20	3.5+100
500.00mA	0.01mA	1.5+20	0.7+20	1.5+20	3.5+100
10.000A	0.001A	1.5+20	0.7+20	3+50	No spec

Current measurement max 10 A within 30 second continuous measurement.

**Frequency** Accuracy  $\pm$  (reading % + LSD)

Function	Range	Accuracy
Frequency	99.999Hz	0.02+5
	999.99Hz	0.02+5
	9.9999kHz	0.02+5
	99.999kHz	0.02+5
	999.99kHz	0.02+5
	3.00MHz	0.05+5

**Resistance** Accuracy  $\pm$  (reading % + LSD)

Function	Range	Resolution	Accuracy
Resistance	50.000 $\Omega$	0.001 $\Omega$	0.05+30
	500.00 $\Omega$	0.01 $\Omega$	0.05+10
	5.0000k $\Omega$	0.0001k $\Omega$	0.05+10
	50.000k $\Omega$	0.001k $\Omega$	0.05+10
	500.00k $\Omega$	0.01k $\Omega$	0.05+10
	5.0000M $\Omega$	0.0001M $\Omega$	0.15+10
	50.000M $\Omega$	0.001M $\Omega$	1.00+10

When measuring low resistance, use the "Relative" function to make accurate measurement

□ **Diode, Continuity**

Function	Range	Resolution	Accuracy
Continuity	50.000Ω	0.001Ω	0.05+20
Diode Test	5.0000V	0.0001V	0.05+10

Buzzer function (Continuity): Buzzer sounds at below 50.0Ω.

□ **Capacitance**

Range	Resolution	Accuracy	Measurement Rate
5.000nF	0.001nF	1+10	4/s
50.00nF	0.01nF	1+10	4/s
500.0nF	0.1nF	1+10	1/s
5.000μF	0.001μF	1+10	1/s
50.00μF	0.01μF	2+10	1/s
500.0μF	0.1μF	3+10	0.1/s
5.00mF	1μF	5+10	0.1/s

When Capacitance value is below 5nF, use “Relative” function to make accurate measurement.

□ **Square Waveform Signal Out**

Output	Range	Resolution	Accuracy
Frequency	10Hz	0.001Hz	0.005%
	100Hz	0.01Hz	
	1kHz	0.1Hz	
	10kHz	<2Hz	
	100kHz	<170Hz	
	1000kHz	<16kHz	
Duty Cycle	5~95%	0.1% <60kHz 1% <600kHz	±0.5%
Amplitude	Fixed(5.0V)	0.1V	±0.2V

Out Put Impedance: Max 3.5kΩ.

Out Put Frequency accuracy is different from Signal Frequency

Duty Cycle and Pulse Width Accuracy is based on 5V Square wave without Signal divide.

## Logic Analyzer

- Input Voltage: 0 ~ 10 V
- Time/div Range: 100ns/div ~ 50ms/div, 1-2-5 Increments
- Sample Rate : Max.50 Mbps per channel
- Memory Depth : 1 kbits/Channel
- Cursor : Supports horizontal cursors
- Trigger Mode : Auto / Norm / Single
- Trigger Source : Ch1, Ch2, Ch3, Ch4, Ch5, Ch6, Ch7, Ch8
- Trigger Level : Auto / Manual
- Trigger Type : Pattern / Duration
- Trigger Condition

Parallel	<ul style="list-style-type: none"> <li>• Supports Pattern/Duration Logic Trigger in combination with all the 8 channels.</li> <li>• Pattern supports Level &amp; Edge selection among 1/0/X/Rising Edge/Falling Edge.</li> <li>• Duration supports Level selection among 1/0/X and Pulse width trigger.</li> </ul>
Logic mode	AND/OR/NAND/NOR
Qualifier	Less than/Greater than/Within/Without

## Protocol Analyzer

- Input Voltage: 0 ~ 10 V
- Time/div Range: 100ns/div ~ 50ms/div, 1-2-5 Increments
- Sample Rate: Max.50 Mbps per channel
- Memory Depth: 1 kbits/Channel
- Cursor: Supports horizontal cursors
- Trigger Mode: Auto / Norm / Single
- Trigger Source: Ch1, Ch2, Ch3, Ch4, Ch5, Ch6, Ch7, Ch8
- Trigger Level: Auto / Manual
- Trigger Type: CAN/LIN/I2C/UART/USB/I2S/SMBus/SPI/DMX512/1-Wire
- Trigger Condition

SEE CHART BELOW

Type	Condition
CAN	Trigger on Start Frame/End Frame, Baud Rate: 10k ~ 1Mbps, Supports only over Protocol CAN2.0
LIN	Trigger on Sync Break, Baud Rate : 2400 ~ 625kbps
I2C	Trigger on Start/Stop/Missing Ack/Restart, Supports 10bit Enable/Disable
UART	Trigger on Start bit/Stop bit/Parity error, Baud Rate: 2400 ~ 921.6kbps
USB	Trigger on SOP/EOP/RC/Suspend/Exit Suspend, Supports only Low/Full Speed
I2S	Trigger on Start bit, WS Selection: Left/Right/Either
SMBus	Trigger on Start/Stop/Missing Ack/Restart, Supports 10bit Enable/Disable
SPI	Trigger on Start bit, Supports 4-Wire SPI, Microwire and other 3-Wire SPIs
DMX512	Trigger on Break Detect/Start bit
1-Wire	Trigger on Reset Detect/Presence Detect/Start bit, Baud Rate: 15.4k/125kbps

### Pattern Generator

- Channel: TX(Output), RX(Input) 2 Channel
- Logic Level: 3.3V CMOS Level Fixed, Logic Positive/Negative
- Pattern:
  - Supports asynchronous serial pattern format of UART, CAN and User defined patterns.
  - Possible to set configuration of Multiple Sending and Interval setting.
- Rate: Max. 1Mbps
- Format: NRZ
- Length: 1024 bits ( limited to User defined mode )

□ **Measurement Rate per function**

Function	Measurement Rate
AC V	7/s
DC V	7/s
AC+DC V	2/s
Ω	14/s
Diode	14/s
Capacitance	4 (< 10μF)/s
DC A	7/s
AC A	7/s
AC+DC A	2/s

**[Input Impedance]**

Function	Range	Input Impedance
DC Voltage	50.000mV	10.00MΩ
	500.00mV	10.00MΩ
	5.0000V	11.10MΩ
	50.000V	10.10MΩ
	500.00V	10.01MΩ
	1000.0V	10.001MΩ
AC Voltage	50.000mV	10.00MΩ
	500.00mV	10.00MΩ
	5.0000V	11.10MΩ
	50.000V	10.10MΩ
	500.00V	10.01MΩ
	1000.0V	10.001MΩ
AC + DC Voltage	50.000mV	10.00MΩ
	500.00mV	10.00MΩ
	5.0000V	11.10MΩ
	50.000V	10.10MΩ
	500.00V	10.01MΩ
	1000.0V	10.001MΩ

5V ~ 1000V range, Dual Display. 10MΩ in parallel  
 Below 100pF in Parallel.

## □ General Specifications

### [Display]

- Max 50,000counts, 240\*160pixel FSTN Display.

### [Power Consumption]

- 1.8W (without B/L), 8Hour Continuous.  
With supplied Ni-MH Battery Pack

### [Environment]

- Temperature: 0°C ~ 50C(Operation Temperature).
- Humidity: 80% RH or less(non-condensing)

### [Storage Temperature]

- -0°C ~ 70°C

### [Safety]

- DMM: Category III 600V, Pollution Degree 2.
- Oscilloscope: Category III 300V, Pollution Degree 2.

### [Temp Coefficient]

- $0.15 \times (\text{Accuracy}) / ^\circ\text{C}$  (0°C ~ 18°C or 28°C ~ 55°C).

### [Dimensions (L×W×H)]

- 203.5 × 94.4 × 59.0mm (8.01" × 3.71" × 2.32")

### [Weight]

- 527 ± 5g (1.2 lbs) Meter only

### [Battery Type]

- 7.2V Ni-MH Rechargeable Battery Pack

### [Charging Time]

- Max 220 minutes at 10°C ~ 30°C.
- When Battery is drain out, full charging time may extend longer time. longer