

PANELBOARD UNIT SCHEDULE

CKT. NO.	DEVICE DESCRIPTION	FRAME AMPS & POLES	SENSOR AMPS	RATING PLUG OR TRIP	CIRCUIT IDENTIFICATION <input type="checkbox"/> CARDHOLDERS <input checked="" type="checkbox"/> NAMEPLATES	NOTE
MIB	SGHA36AT0400-SRPG400A400	400/3	400A	400A	MAINTENANCE ISOLATION BREAKER	8,11
MBB	SGHA36AT0400-SRPG400A400	400/3	400A	400A	MAINTENANCE BYPASS BREAKER	8, 11
BIB	SGHA36AT0400-SRPG400A400	400/3	400A	400A	BYPASS ISOLATION BREAKER	8

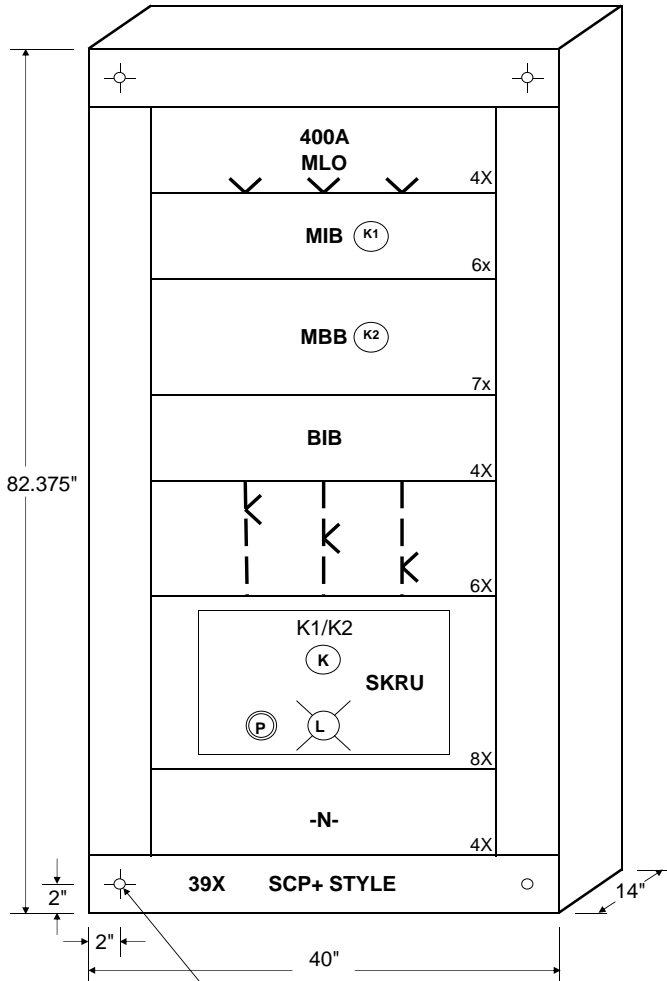

FRONT VIEW

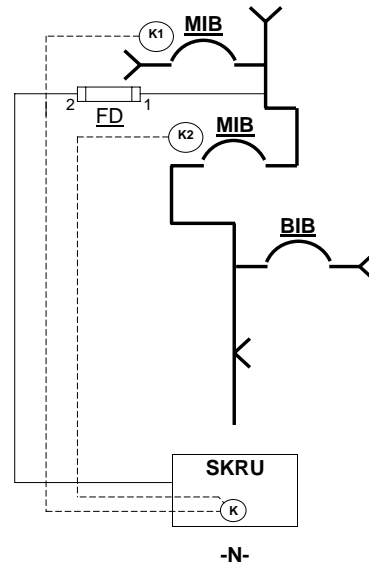

-N-
PANELBOARD BUS IS 400A

BUSSING DIAGRAM

MAINTENANCE BYPASS PANELBOARD	
AMPERES: 400A	
VOLTAGE: 277/480V	PHASE: 3PH 4W 60 HZ.
LABEL: U/L	FINISH: ANSI61
BUS MAT'L & PLATE: COPPER-SILVER	
BUS BRACING RMS SYM: 65,000 AMPS	
SHORT CIRCUIT RATING: 35,000 AMPS	

SBS Battery UPS MBP UPB3400A1S
PO No. 0
PO No. 0
GE REQ No. 0

BOX: DACB 4045 SCP 14"	QTY 1
FRONT: ACF 4045S (19")	PNL ASM

S Storage Battery Systems	REL.: TB	ISSUED: TB			MemF PLANT	177 PP 0	lt. 1
	DATE: 1/19/05	DATE: 1/19/05				CONTINUED ON SHEET NO. 2	SHEET NO. 1