

NOTES:

1. MATERIAL: 7 GA HRPO FRAMES AND RAILS, 10 GA DIAGONAL BRACES
2. FINISH: POWDER COAT ASA 61 GRAY, TEXTURE
3. APPROXIMATE WEIGHT: 90 LBS. (RACK ONLY, UNPACKAGED)
4. DRAWING SHOWN WITH SEISMIC MOUNTING BRACKETS AND HARDWARE.
5. FRAME CONSTRUCTION, BATTERY SUPPORT RAIL DESIGN, AND SEISMIC BRACKET OPTIONS ARE SEISMIC CERTIFIED TO THE UNIFORM BUILDING CODE (UBC).
6. **WHEN ORDERING RACKS WITH SEISMIC OPTION, ADD (-Z4) AFTER THE MODEL NUMBER.**

REVISIONS			
REV.	DESCRIPTION	DATE	APPROVED
A	INITIAL RELEASE	7/21/2009	RNA
4	REMOVED OPTION FOR MARINE / TELECOM HOLD DOWN BARS FROM DRAWING	2/4/2011	RNA

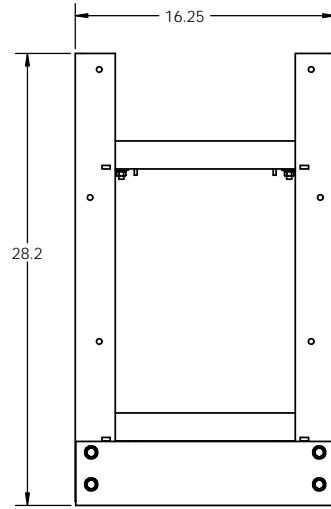
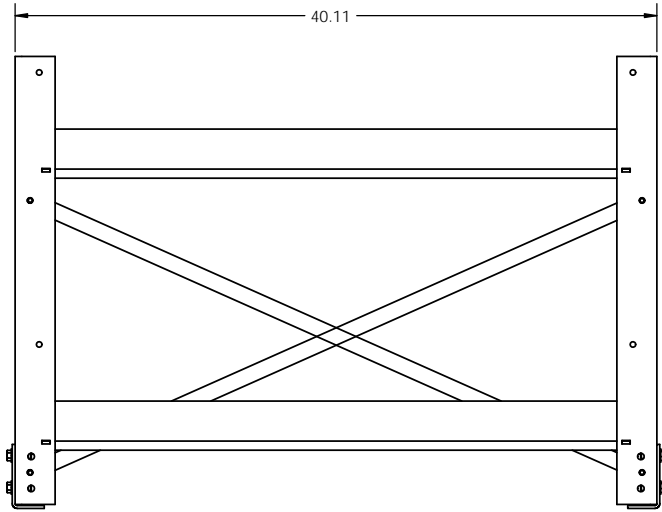

BATTERIES SHOWN FOR REFERENCE ONLY. SOLD SEPARATELY.

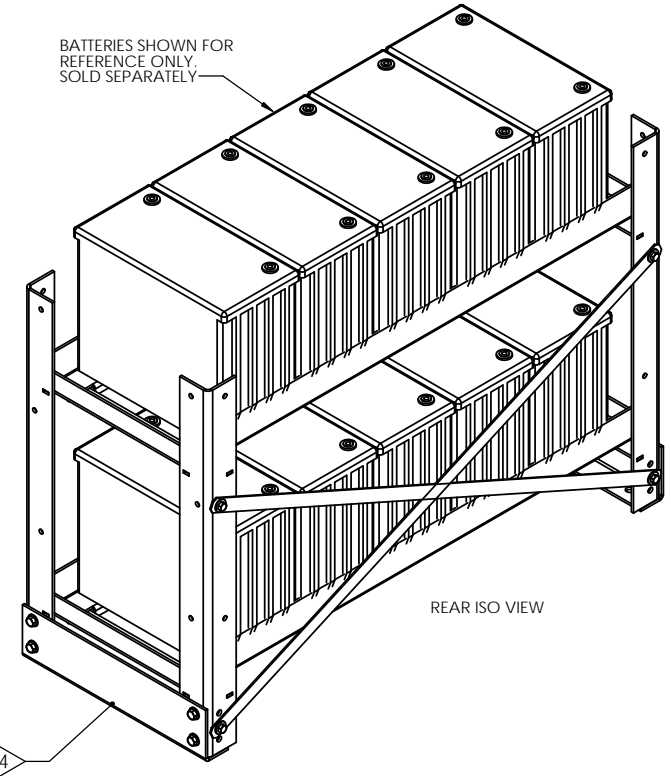

REAR ISO VIEW

Part# VR-2T5W
Holds qty.10 VRLA Batteries

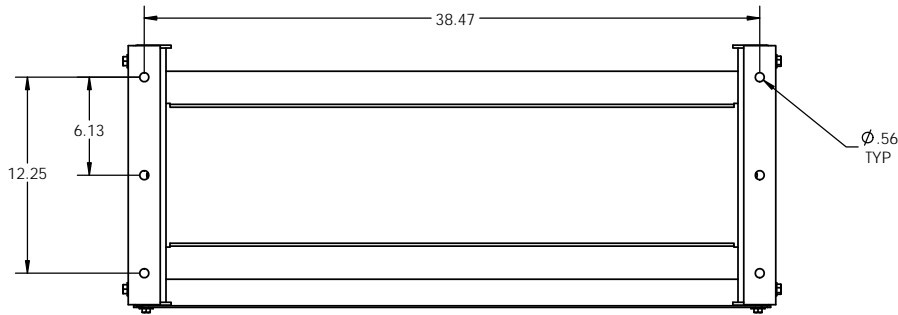

BOTTOM VIEW
OPTIONAL SEISMIC MOUNTING FOOTPRINT