

# **OWNER'S MANUAL 193111-053**

Revised JULY 2, 2003

---

**IMPORTANT:** Read this manual before installing, operating, or servicing this product.

---

# **Power Mate**

**DO NOT DESTROY**

---

**IMPORTANT: SAVE THIS SAFETY AND INSTRUCTION MANUAL.  
IMMEDIATELY REPLACE WHEN WORN OR LOST.**

---

**AMETEK/PRESTOLITE POWER, TROY, OHIO 45373-1099, U.S.A.**

## **GENERAL SAFETY PRACTICES FOR ANY ELECTRICAL EQUIPMENT**

1. READ THE SPECIFIC **SAFETY INSTRUCTIONS AND WARNINGS** CHAPTER OF THIS MANUAL BEFORE INSTALLING AND USING THE EQUIPMENT.
2. READ AND RETAIN THE OWNER'S MANUAL – All the safety and operating instructions should be read and understood before using the equipment.
3. FOLLOW INSTRUCTIONS – All installation, operating and maintenance instruction should be followed.
4. WATER AND MOISTURE – The equipment should not be used near water – for example, near a washbowl, steam cleaning equipment or in any wet or damp area.
5. VENTILATION – The equipment should be situated such that its location or position does not interfere with its required ventilation.
6. HEAT – The equipment should be situated away from heat sources such as radiators, heat registers, or any other equipment that produces heat.
7. POWER SOURCE – The equipment should be connected to a source of power only as described in the Owner's Manual.
8. GROUNDING – Precautions should be taken to insure the equipment grounding means is not defeated.
9. POWER CORD AND CHARGING CABLES PROTECTION – Power supply and charging cables should be routed to prevent them from being walked on, pinched by other equipment, or driven over.
10. CLEANING – Cleaning should only be performed as instructed in the Owner's Manual.
11. NON-USE PERIODS – The power cord should be unplugged from the outlet and the battery should be disconnected from the charger if the equipment is to be left unused for a long period of time.
12. OBJECT AND LIQUID ENTRY – Care should be taken so objects do not fall or liquids are not spilled into cabinet openings.
13. DAMAGE REQUIRING SERVICE – The equipment should be serviced by qualified service personnel when:
  - A. Power cord or plug, charging cables or connector have been damaged.
  - B. Objects have fallen into, or liquid has been spilled into the equipment.
  - C. The equipment has been dropped, or the cabinet damaged.
  - D. The equipment does not appear to operate normally or exhibits a marked change in performance.
14. REPLACEMENT PARTS – When replacement parts are needed, be sure only replacement parts specified by the manufacturer are used. Unauthorized substitutions may result in fire, electric shock, or other hazards.

**GENERAL SAFETY PRACTICE  
FOR ANY ELECTRICAL EQUIPMENT**

**Inside Front Cover**

**SAFETY INSTRUCTIONS AND WARNINGS ..... 1**

- A. GENERAL..... 1-1
- B. SHOCK PREVENTION..... 1-1
- C. BURN AND BODILY INJURY PREVENTION ..... 1-2
- D. FIRE AND EXPLOSION PREVENTION ..... 1-2
- E. ARCING AND BURNING OF CONNECTOR ..... 1-2
- F. MEDICAL AND FIRST AID TREATMENT ..... 1-2
- G. EQUIPMENT WARNING LABELS..... 1-2

**INTRODUCTION ..... 2**

- A. HOW TO USE THIS MANUAL ..... 2-1
- B. EQUIPMENT IDENTIFICATION ..... 2-1
- C. RECEIPT OF EQUIPMENT ..... 2-1

**INSTALLATION ..... 3**

- A. LOCATION ..... 3-1
- B. SAFETY..... 3-1
- C. GROUNDING ..... 3-1
- D. ELECTRICAL INPUT REQUIREMENTS..... 3-1
- E. CHARGING CABLE CONNECTORS..... 3-1
- F. CONNECTION TO AC POWER..... 3-1

**OPERATION ..... 4**

- A. PRELIMINARY ..... 4-1
- B. DAILY CHARGE ..... 4-1
- C. BATTERY DISCONNECT SHUTDOWN ..... 4-1
- D. AC POWER FAIL..... 4-1

**MAINTENANCE ..... 5**

**SERVICE ..... 6**

**BATTERY CHARGING QUESTIONS AND ANSWERS..... 7**

**PARTS LIST ..... 8**

**DIAGRAMS**

**WARRANTY**

**This page intentionally left blank.**

# SAFETY INSTRUCTIONS AND WARNINGS

## FOR OPERATION OF BATTERY CHARGING EQUIPMENT

**IMPORTANT – READ AND UNDERSTAND THESE INSTRUCTIONS. DO NOT LOSE THEM. ALSO READ OPERATING/INSTRUCTION MANUAL BEFORE INSTALLING, OPERATING, OR SERVICING THIS EQUIPMENT.**

### A. General

Battery charging products can cause serious injury or death, or damage to other equipment or property, if the operator does not strictly observe all safety rules and take precautionary actions.

Safe practices have developed from past experience in the use of charging equipment. These practices must be learned through study and training before using this equipment. Anyone not having extensive training in battery charging practices should be taught by experienced operators.

Only qualified personnel should install, use, or service this equipment.

### B. Shock Prevention

Bare conductors, or terminals in the output circuit, or ungrounded, electrically-live equipment can fatally shock a person. To protect against shock, have competent electrician verify that the equipment is adequately grounded and learn what terminals and parts are electrically HOT.

The body's electrical resistance is decreased when wet, permitting dangerous current to flow through the body. Do not work in damp area without being extremely careful. Stand on dry rubber mat or dry wood and use insulating gloves when dampness or sweat cannot be avoided. Keep clothing dry.

1. Installation and Grounding of Electrically Powered Equipment – Electrical equipment must be installed and maintained in accordance with the National Electrical Code, NFPA 70, and local codes. Check nameplate for voltage and current requirements.

Do not remove or bypass a ground prong from any plug. Always use correct mating receptacles. Check ground for electrical continuity before using equipment.

2. Charging Leads – Inspect leads often for damage to the insulation. Replace or repair cracked or worn leads immediately. Use leads having sufficient capacity to carry the operating current without overheating.

3. Battery Terminals – Do not touch battery terminals while equipment is operating.

4. Service and Maintenance – Shut OFF all power at the disconnect switch or line breaker *before* inspecting, adjusting, or servicing the equipment. Unplug power cord from AC power receptacle so that the power cannot be turned ON accidentally. Disconnect power to equipment if it is to be left unattended or out of service.

Disconnect battery from charger.

Keep inside parts clean and dry. Dirt and/or moisture can cause insulation failure. This failure can result in high voltage at the charger output.

### C. Burn And Bodily Injury Prevention

The battery produces very high currents when short circuited, and will burn the skin severely if in contact with any metal conductor that is carrying this current. Do not permit rings on fingers to come in contact with battery terminals or the cell connectors on top of the battery.

Battery acid is very corrosive. Always wear correct eye and body protection when near batteries.

### D. Fire And Explosion Prevention

Batteries give off explosive flammable gases which easily ignite when coming in contact with an open flame or spark. Do not smoke, cause sparking, or use open flame near batteries. Charge batteries only in locations which are clean, dry, and well ventilated. Do not lay tools or anything that is metallic on top of any battery. All repairs to a battery must be made only by experienced and qualified personnel.

### E. Arcing And Burning Of Connector

To prevent arcing and burning of the connector contacts, be sure the charger is OFF before connecting or disconnecting the battery. (If the charger is equipped with an ammeter, the ammeter should not indicate current flow.) Always connect battery before turning charger ON.

### F. Medical And First Aid Treatment

First aid facilities and a qualified first aid person should be available for each shift for immediate treatment of electrical shock victims.

**EMERGENCY FIRST AID: Call physician and ambulance immediately. Use First Aid techniques recommended by the American Red Cross.**

**DANGER: ELECTRICAL SHOCK CAN BE FATAL. If person is unconscious and electric shock is suspected, do not touch person if he or she is in contact with charging leads, charging equipment, or other live electrical parts. Disconnect (open) power at wall switch and then use First Aid. Dry wood, wooden broom, and other insulating material can be used to move cables, if necessary, away from person. IF BREATHING IS DIFFICULT, give oxygen. IF NOT BREATHING, BEGIN ARTIFICIAL BREATHING, such as mouth-to-mouth. IF PULSE IS ABSENT, BEGIN ARTIFICIAL CIRCULATION, such as external heart massage.**

IN CASE OF ACID IN THE EYES, flush very well with clean water and obtain professional medical attention immediately.

### G. Equipment Warning Labels

Inspect all precautionary labels on the equipment. Order and replace all labels that cannot be easily read.

# INTRODUCTION

## A. How To Use This Manual

To ensure safe operation, read the entire manual, including the chapter on safety instructions and warning.

**IMPORTANT: It is especially important that all charger internal components be kept clean and dry, and all electrical connections tightened. Replace any precautionary or instruction label that cannot be easily read.**

Throughout this manual, the words **WARNING**, **CAUTION**, and **NOTE** may appear. Pay particular attention to the information provided under these headings. These special annotations are easily recognized as follows:

**WARNING gives information regarding possible personal injury. Warnings will be enclosed in a box such as this.**

**CAUTION** refers to possible equipment damage. **Cautions will be shown in bold type.**

*NOTE offers helpful information concerning certain operating procedures. Notes will be shown in italics.*

## B. Equipment Identification

The unit's identification number (specification, model, serial number) usually appears on a data plate on the front (or rear) of the charger.

## C. Receipt Of Equipment

When you receive the equipment, check it against the invoice to make sure it is complete and inspect the equipment for possible damage due to shipping. If there is any damage, notify the carrier immediately to file a claim. Furnish complete information concerning damage claims or shipping errors to the company shown on the cover of this manual. Include all equipment identification numbers and group part numbers (if any) as described above along with a full description of the parts in error.

**This page intentionally left blank.**



# INSTALLATION

## A. Location

**FIRE HAZARD – As with any electrical power equipment, do not install on or over combustible materials. Keep charging area clear of combustible materials.**

The charger must be installed indoors. Avoid locations exposed to high humidity, dust or ambient temperatures above 40°C. (104°F.)

Adequate air circulation is required to insure proper operation and long life. A minimum of 6 inches of free air space should be provided at both sides and rear of cabinet.

## B. Safety

Refer to additional installation instructions under the SAFETY INSTRUCTIONS AND WARNINGS Section of this manual.

## C. Grounding

The charger is provided with a 3 prong, grounding type plug on the AC input cord. The plug must only be used with a properly installed and grounded mating receptacle to insure user safety. It is the responsibility of the user to provide such a receptacle and that its installation meets all appropriate electrical codes.

## D. Electrical Input Requirements

The AC input voltage and line draw is provided on a data plate located on the front of the charger. The charger is provided with the proper AC cord and plug. Connect the AC input plug to an appropriate receptacle that is properly grounded.

## E. Charging Cable Connectors

If connectors are already connected to the charging cables, make sure that they are attached so the charger positive polarity will connect to the positive terminal of the battery.

*NOTE: The polarity of the charging cable is color-coded. The white cable is positive and the black cable is negative.*

If connectors must be attached to charging cables, follow instructions supplied with connectors.

**CAUTION: Improper connections may “blow” charger output fuse and may cause other damage. Loose connections will reduce charger performance. Be certain the charger positive charging cable will connect to the positive terminal of the battery. Make sure connectors are securely attached to cable (good solder connects, well tightened set screws or proper crimp, whichever is available).**

## F. Connection To AC Power

After reading and following the installation instructions above, plug the charger AC input into the AC power receptacle.

**This page intentionally left blank.**

# OPERATION

## A. Preliminary

Make sure the charger is installed and grounded as instructed in the INSTALLATION chapter of this manual.

When charging flooded (wet-type) batteries, maintain the electrolyte level in the batteries to be charged, as instructed by the battery manufacturer. Insure the battery size matches the charger.

When charging sealed batteries (Gel or AGM), always be sure that the charger is properly set to the battery type being charged.

Battery number of cells (voltage) must equal the number of cells (voltage) stated on the charger data plate.

Battery ampere-hour capacity must be within the ampere-hour range stated on the charger data plate.

**CAUTION: The charging of a battery with the incorrect number of cells or an ampere-hour capacity outside the range stated on the charger data plate will result in severe over or under charging of the battery, resulting in reduced battery performance and life.**

**CAUTION: The charging of a sealed battery (Gel or AGM) with incorrect charger settings will cause battery venting resulting in reduced battery performance and life.**

## B. Daily Charging

**WARNING: Do not disconnect a battery from this charger while a charge is in progress; otherwise, arcing and burning of connector parts or a battery explosion may result. Batteries produce explosive gases. Keep sparks, flame, and cigarettes away. Ventilate when charging in an enclosed area. Always shield eyes when working near batteries.**

1. Insure the battery size matches the charger (Battery voltage and ampere hour capacity are within nameplate information).
2. Securely engage the battery and charger connectors.
3. After a short delay, the charger will turn on. The ammeter will indicate charging current.
4. The charger will automatically turn off when the charge is complete.

*NOTE: To disconnect battery from charger before charge is complete, first disconnect the input AC cord from the input power source.*

## C. Battery Disconnect Shutdown

If the battery is disconnected from the charger during a charge cycle, the charger will shutdown.

## D. AC Power Failure

During an AC power failure, the charger stores key information about the charge cycle. This information allows the charger to resume charging where it left off when the AC power is returned.

**This page intentionally left blank.**

# MAINTENANCE

**WARNING: ELECTRIC SHOCK CAN BE FATAL – Before performing maintenance procedures, turn charger OFF and unplug from AC power, disconnect battery and check for voltage on capacitor (s). Discharge capacitor (s) with insulated screwdriver if there is any voltage present.**

For uninterrupted, satisfactory service, it's necessary to keep the charger clean, dry, and well ventilated. At least every year, or more often if necessary, wipe and blow out all dirt from charger's interior components with clean, dry air of not over 25 psi (172 kPa). Use a hand bellows if compressed air is not available.

While charger cabinet is removed, check for broken wiring and damaged insulation on wiring. If any is observed, do not use charger until a qualified service person has repaired the charger.

Be sure all cabinet panels have been replaced before using charger.

**This page intentionally left blank.**

# SERVICE

There are no user serviceable parts within the charger. Refer all service needs to an authorized Ametek Service Center. To avoid delays, have the charger specification no., model no., and serial no. available before contacting a Service Center. For the closest Service Center, write or call:

**Ametek/Prestolite Power**

2220 Corporate Drive  
Troy, Ohio  
45373

Phone 1-800-852-8689

**This page intentionally left blank.**



---

# BATTERY CHARGING QUESTIONS AND ANSWERS

## 1. How often should I charge my battery?

This is a very difficult question to answer as every application can be different. The health of the battery, the battery ampere-hour capacity and its relationship to the vehicle, the relationship of the battery ampere-hour capacity to the charger ampere-hour capacity, and the daily number of hours of vehicle use all influence how often the battery should be charged.

Many vehicles are equipped with “fuel” gauges and notify the operator when the battery should be charged. Fuel gauges typically suggest charging the battery when it is 80% discharged.

If the vehicle is not equipped with fuel gauge, most batteries are sized to a vehicle to provide approximately 6 hours of typical use. If you make continuous use of the vehicle all day long, then daily charging is recommended. If you use the vehicle 3 – 4 hours a day, then charging every other day makes sense. If the vehicle use is only occasional, then charging every weekend may be adequate.

If your vehicle use is sporadic and unpredictable, charge the battery when a decrease in vehicle performance is observed. A decrease in performance may be evidenced by slowing of forward speed, sluggish lifting of the forks or personnel lift, poor sweeping or a general slowing down of the battery powered equipment.

**CAUTION: The proper charging of the battery is very important to obtaining expected battery life. Over-discharging and over/under-charging batteries are the leading causes of early battery failure. You have taken a good step in insuring battery life with the purchase of this charger. An excellent second step is to have a quality fuel gauge installed on the vehicle and use it. And finally, maintain the battery in accordance with the battery manufacturer’s recommendations.**

## 2. How long should it take to charge my battery?

Again, this is a very difficult question to answer as every application can be different. The relationship of the battery ampere-hour capacity to the charger ampere-hour capacity and the depth of discharge of the battery together dictate how long it will take to charge. It may take as little as 3 hours or as long as 14 hours.

**CAUTION: The charging of a battery with an ampere-hour capacity outside the range stated on the charger data plate will result in severe over or under charging of the battery resulting in reduced battery performance and life.**

# PARTS LIST

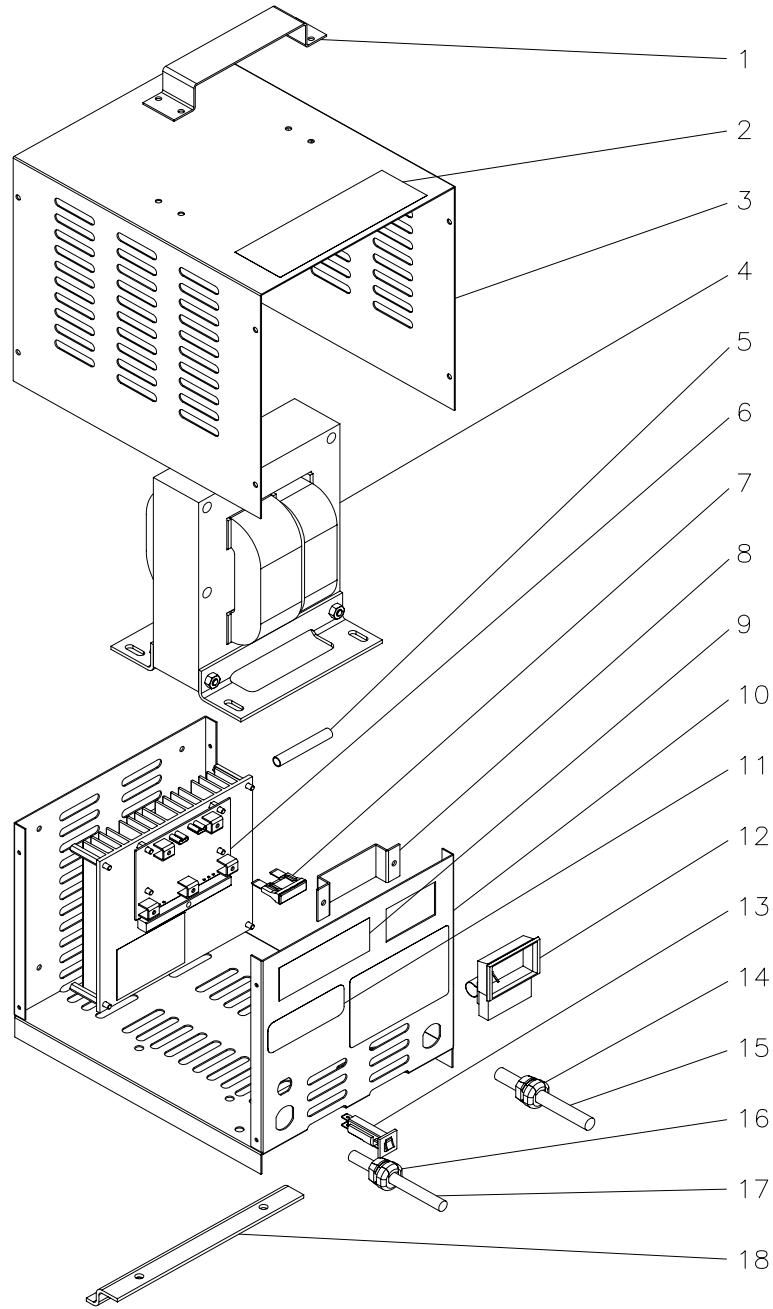

## POWER MATE

Item No.	Item Description	500682-1 20-12CC	500682-2 20-12CAN	500644-1 20-24CC	500644-2 20-24CAN	500645-1 25-24CC	500645-2 25-24CAN	500646-1 20-36CC	500646-2 20-36CAN	500647-2 25-36CAN	500656-1 15-48CC	500656-2 15-48CAN
		Part No.	Part No.	Part No.	Part No.	Part No.	Part No.	Part No.	Part No.	Part No.	Part No.	Part No.
1	Handle	195906	195906	195906	195906	195906	195906	195906	195906	195906	195906	195906
2	Label, Danger	196175	196175	196175	196175	196175	196175	196175	196175	196175	196175	196175
3	Panel, Top & Sides	195889	195889	195889	195889	195889	195889	195889	195889	195889	195889	195889
4	Transformer	196392	196392	195902	195902	195903	195903	195904	195904	195905	196092	196092
5	Tubing, Heat Shrink	194814-1	194814-1	194814-1	194814-1	194814-1	194814-1	194814-1	194814-1	194814-1	194814-1	194814-1
6	Kit, PC Board, Ay.	196051	196051	196051	196051	196051	196051	196051	196051	196051	196051	196051
7	Fuse, DC	196023-1	196023-1	196023-1	196023-1	196023-1	196023-1	196023-1	196023-1	196023-1	196023-1	196023-1
8	Bracket, Ammeter	195916	195916	195916	195916	195916	195916	195916	195916	195916	195916	195916
9	Label, Prestolite Power	196034	196034	196034	196034	196034	196034	196034	196034	196034	196034	196034
10	Panel, Bottom	195890	196164	195890	196164	195890	196164	195890	196164	196164	195890	196164
11	Label, UL	196177	404079	196177	404079	196177	404079	196177	404079	404079	196177	404079
12	Ammeter	195540-3	195540-3	195540-3	195540-3	195540-3	195540-3	195540-3	195540-3	195540-3	195540-3	195540-3
13	Circuit Breaker	196031-4	196031-4	196031-1	196031-1	196031-2	196031-2	196031-2	196031-2	196031-3	196031-2	196031-2
14	Bushing, Strain Relief	TRY119-1	TRY119-1	TRY119-1	TRY119-1	TRY119-1	TRY119-1	TRY119-1	TRY119-1	TRY119-1	TRY119-1	TRY119-1
15	Cable, Charging	409813-11	409813-11	409813-11	409813-11	409813-11	409813-11	409813-11	409813-11	409813-11	409813-11	409813-11
16	Bushing, Strain Relief	TRY119-1	W10080-3	TRY119-1	W10080-3	TRY119-1	W10080-3	TRY119-1	W10080-3	W10080-3	TRY119-1	W10080-3
17	AC Cord & Plug	409813-10	409813-13	409813-10	409813-13	409813-10	409813-13	409813-10	409813-13	409813-12	409813-10	409813-13
18	Bracket, Mounting	195891	195891	195891	195891	195891	195891	195891	195891	195891	195891	195891
19	Sleeving, Output Leads, 13" & 24" (Not Shown)	043505	043505	043505	043505	043505	043505	043505	043505	043505	043505	043505

POWER MATE  
PARTS LIST

**This page intentionally left blank.**





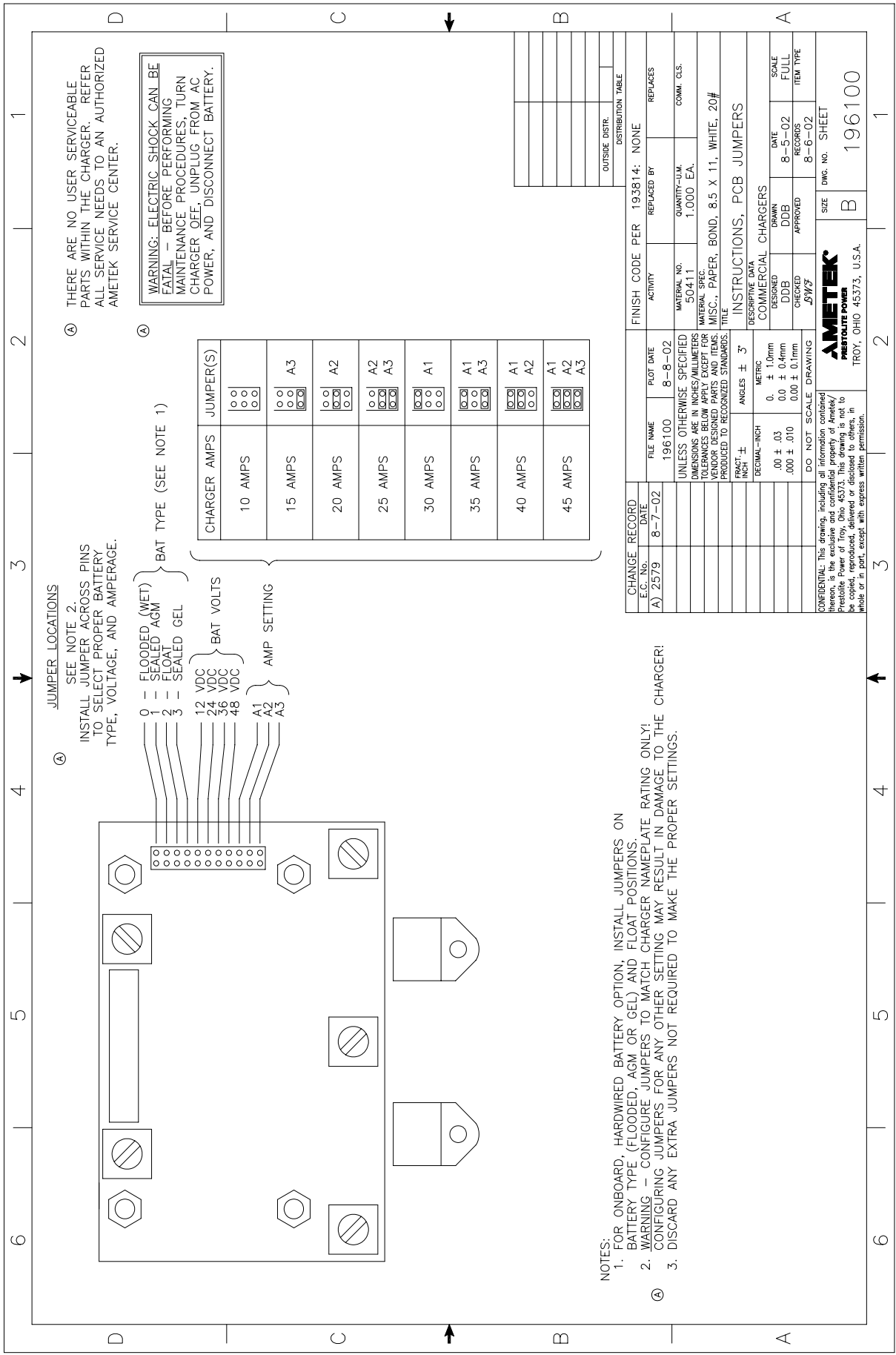

- NOTES:
- FOR ONBOARD, HARDWIRED BATTERY OPTION, INSTALL JUMPERS ON BATTERY TYPE, (FLOODED, AGM OR GEL) AND FLOAT POSITIONS.
  - WARNING — CONFIGURE JUMPERS TO MATCH CHARGER NAMEPLATE RATING ONLY! CONFIGURING JUMPERS FOR ANY OTHER SETTING MAY RESULT IN DAMAGE TO THE CHARGER!
  - DISCARD ANY EXTRA JUMPERS NOT REQUIRED TO MAKE THE PROPER SETTINGS.

CHANGE RECORD E.C. NO. DATE	FILE NAME	PLOT DATE	FINISH CODE PER
A) 2579 8-7-02	196100	8-8-02	193814: NONE
UNLESS OTHERWISE SPECIFIED		MATERIAL NO.	REPLACES
DIMENSIONS ARE IN INCHES/MILLIMETERS		50411	QUANTITY-LIM.
UNLESS OTHERWISE SPECIFIED		1.000 EA.	COMM. Q.S.
VENDOR DESIGNED PARTS AND ITEMS		MATERIAL SPEC.	
PRODUCED TO RECOGNIZED STANDARDS.		MISC., PAPER, BOND, 8.5 X 11, WHITE, 20#	
		TITLE	
		INSTRUCTIONS, PCB JUMPERS	
		DESCRIPTION DATA	
		COMMERCIAL CHARGERS	
		DESIGNED	DATE
		DOB	8-5-02
		CHECKED	RECORDS
		SWZ	8-6-02
		APPROVED	ITEM TYPE
CONFIDENTIAL: This drawing, including all information contained hereon, is the exclusive and confidential property of Ametek/Prestolite Power of Troy, Ohio 45373. This drawing is not to be copied, reproduced, delivered or disclosed to others, in whole or in part, except with express written permission.		SIZE	DWG. NO.
		B	196100
		<b>AMETEK</b> PRESTOLITE POWER TROY, OHIO 45373, U.S.A.	









# WARRANTY

## Power Mate

**AMETEK/Prestolite Power warrants that each new and unused Power Mate (the “Product”) manufactured and supplied by it is of good workmanship and is free from any inherent mechanical defects, provided that:**

- A. The Product is installed and operated in accordance with generally accepted industrial standards and in accordance with the enclosed printed instructions.
- B. The Product is used under normal conditions for which designed.
- C. The Product is not subjected to misuse, negligence or accident.
- D. The Product receives proper care, protection and maintenance under supervision of competent personnel.

The warranty is subject to the following conditions:

1. **TERMS OF WARRANTY.** Subject to the exceptions listed below, the Product is warranted for two (2) years, provided that the Product is used in accordance with the manufacturer’s published performance rating for the unit involved. During said period a product found to be defective will be repaired or replaced FOB Factory, 2220 Corporate Drive Troy, OH 45373
2. **PERSONS COVERED BY WARRANTY.** This warranty is extended by the manufacturer only to the purchaser of new Product from the manufacturer or one of its authorized distributors. The products purchased under this agreement shall be used exclusively by the purchaser and its employees and by no other persons, and therefore there shall be no third party beneficiary to this warranty.
3. **LIMITATION OF REMEDY.** The existence of claimed defects in any Product covered by this warranty is subject to factory inspection and judgment. The manufacturer’s liability is limited to repair of any defects found by the factory to exist or, at the manufacturer’s option, the replacement of the defective Product after the defective Product has been returned by the purchaser at its expense to the factory. Replacement and exchange parts will be warranted for the remainder of the original manufacturer Product Warranty, or for a period of ninety (90) days, whichever is greater.
4. **FOR REPAIRS MADE AT OTHER THAN THE FACTORY, AMETEK will provide only the replacement parts.** Defective parts should be sent with transportation charges prepaid to AMETEK factory as shown above.

THE MANUFACTURER AND ITS AUTHORIZED DISTRIBUTORS OR DEALERS SHALL NOT BE LIABLE FOR DIRECT OR INDIRECT, SPECIAL OR CONSEQUENTIAL DAMAGES, INCLUDING BUT NOT LIMITED TO, EXPENSES FOR TELEPHONE CALLS, TELEGRAMS, TRAVEL, LODGING, DUTIES AND TAXES, LABOR, RENTAL OR REPLACEMENT EQUIPMENT, LOSS OF BUSINESS OR PROFITS OR OTHER COMMERCIAL LOSSES.

5. **USE OF DEFECTIVE PRODUCT.** Continued use of the Product after discovery of a defect VOIDS ALL WARRANTIES.
6. **ALTERED EQUIPMENT.** Except as authorized in writing, the warranty specified does not cover any product that has been altered by any party other than the factory.

**EXCEPT AS STATED ABOVE, ALL OTHER WARRANTIES AND CONDITIONS, WHETHER EXPRESSED OR IMPLIED, INCLUDING IMPLIED WARRANTIES OF MERCHANTABILITY AND FITNESS FOR A PARTICULAR PURPOSE, ARE EXCLUDED. To ensure safe operation, equipment must be installed and serviced by skilled, qualified personnel and in accordance with all federal, state, and local electrical codes. The manufacturer neither assumes nor authorizes any person(s) to assume for the manufacturer any other liability in connection with the sale or use of the goods sold, and there are no oral agreements or warranties collateral to or affecting this written warranty.**

**AMETEK/Prestolite Power Corporation  
Troy, Ohio USA**

Data Sheet: 1151  
Index: 033103  
Replaces: 080102

 **AMETEK®**  
PRESTOLITE POWER

